

**DVD HOME THEATER SOUND SYSTEM  
SYSTEME HOME CINEMA DVD**

---

# DVX-S301

(DVR-S300 + NX-SW301 + NX-S301 + NX-C301)

# DVX-S302

(DVR-S300 + NX-SW301 + NX-S302 + NX-C302)

# DVX-S303

(DVR-S300 + NX-SW300 + NX-S302 + NX-C302)





Active Servo Processing Subwoofer System with a built-in power amplifier. The subwoofer system (NX-SW300 and NX-SW301) employs Advanced Yamaha Active Servo Technology which YAMAHA has developed for reproducing higher quality super-bass sound. This super-bass sound adds a more realistic, theater-in-the-home effect to your stereo system.

## Sound field features



Manufactured under license from Dolby Laboratories. “Dolby”, “Pro Logic”, “MLP Lossless” and the double-D symbol are trademarks of Dolby Laboratories.



“DTS” and “DTS Digital Surround” are registered trademarks of Digital Theater Systems, Inc.



“DivX”, “DivX Certified”, and associated logos are trademarks of DivXNetworks, Inc and are used under license.



This product incorporates copyright protection technology that is protected by method claims of certain U.S. patents and other intellectual property rights owned by Macrovision Corporation and other rights owners. Use of this copyright protection technology must be authorized by Macrovision Corporation, and is intended for home and other limited viewing uses only unless otherwise authorized by Macrovision Corporation. Reverse engineering or disassembly is prohibited.

## Playable disc formats

This receiver can play the disc types associated with the logos shown below. (Do not attempt to load any other type of disc into the receiver, or the receiver may be damaged.)



# IMPORTANT SAFETY INSTRUCTIONS

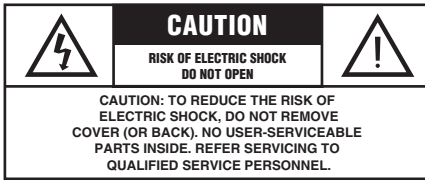

## \* Explanation of Graphical Symbols



The lightning flash with arrowhead symbol, within an equilateral triangle, is intended to alert you to the presence of uninsulated “dangerous voltage” within the product’s enclosure that may be of sufficient magnitude to constitute a risk of electric shock to persons.



The exclamation point within an equilateral triangle is intended to alert you to the presence of important operating and maintenance (servicing) instructions in the literature accompanying the appliance.

### IMPORTANT

Please record the serial number of this unit in the space below.

MODEL:

Serial No.:

The serial number is located on the bottom of the unit.

Retain this Owner’s Manual in a safe place for future reference.

- 1 Read these instructions.
- 2 Keep these instructions.
- 3 Heed all warnings.
- 4 Follow all instructions.
- 5 Do not use this apparatus near water.
- 6 Clean only with dry cloth.
- 7 Do not block any ventilation openings. Install in accordance with the manufacturer’s instructions.
- 8 Do not install near any heat sources such as radiators, heat registers, stoves, or other apparatus (including amplifiers) that produce heat.
- 9 Do not defeat the safety purpose of the polarized or grounding-type plug. A polarized plug has two blades with one wider than the other. A grounding type plug has two blades and a third grounding prong. The wide blade or the third prong are provided for your safety. If the provided plug does not fit into your outlet, consult an electrician for replacement of the obsolete outlet.
- 10 Protect the power cord from being walked on or pinched particularly at the plugs, convenience receptacles, and the point where they exit from the apparatus.
- 11 Only use attachments/accessories specified by the manufacturer.
- 12 Use only with the cart, stand, tripod, bracket, or table specified by the manufacturer, or sold with the apparatus. When a cart is used, use caution when moving the cart/apparatus combination to avoid injury from tip-over. 
- 13 Unplug this apparatus during lightning storms or when unused for a long periods of time.
- 14 Refer all servicing to qualified service personnel. Servicing is required when the apparatus has been damaged in any way, such as power-supply cord or plug is damaged, liquid has been spilled or objects have fallen into the apparatus, the apparatus has been exposed to rain or moisture, does not operate normally, or has been dropped.
- 15 Be sure to allow spaces of at least 10 cm above, behind and on both sides of DVR-S300, and at least 1m above, 30cm behind and on both sides of NX-SW300 and NX-SW301.
- 16 Do not place the following objects on this unit:  
A vessel with water in it.  
If the vessel falls by vibrations and water spills, it may cause damage to the unit, and/or you may get an electric shock. Apparatus shall not be exposed to dripping or splashing.

## FCC INFORMATION (for US customers)

**1 IMPORTANT NOTICE: DO NOT MODIFY THIS UNIT!**

This product, when installed as indicated in the instructions contained in this manual, meets FCC requirements. Modifications not expressly approved by Yamaha may void your authority, granted by the FCC, to use the product.

**2 IMPORTANT:** When connecting this product to accessories and/or another product use only high quality shielded cables. Cable/s supplied with this product **MUST** be used. Follow all installation instructions. Failure to follow instructions could void your FCC authorization to use this product in the USA.

**3 NOTE:** This product has been tested and found to comply with the requirements listed in FCC Regulations, Part 15 for Class "B" digital devices.

Compliance with these requirements provides a reasonable level of assurance that your use of this product in a residential environment will not result in harmful interference with other electronic devices. This equipment generates/uses radio frequencies and, if not installed and used according to the instructions found in the users manual, may cause interference harmful to the operation of other electronic devices. Compliance with FCC regulations does not guarantee that interference will not occur in all installations. If this product is found to be the source of interference, which can be determined by turning the product "OFF" and "ON", please try to eliminate the problem by using one of the following measures:

Relocate either this product or the device that is being affected by the interference.

Utilize power outlets that are on different branch (circuit breaker or fuse) circuits or install AC line filter/s.

In the case of radio or TV interference, relocate/reorient the antenna. If the antenna lead-in is 300 ohm ribbon lead, change the lead-in to coaxial type cable.

If these corrective measures do not produce satisfactory results, please contact the local retailer authorized to distribute this type of product. If you can not locate the appropriate retailer, please contact Yamaha Electronics Corp., 6660 Orangethorpe Ave. Buena Park, CA90622.

The above statements apply **ONLY** to those products distributed by Yamaha Corporation of America or its subsidiaries.

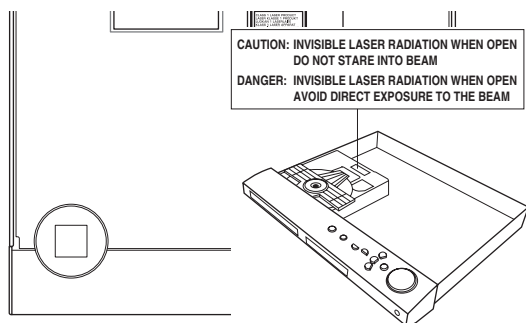

**CAUTION**

Use of controls or adjustments or performance of procedures other than those specified herein may result in hazardous radiation exposure.

**SÉCURITÉ LASER**

L'appareil utilise un laser. En raison des risques de blessure des yeux, le retrait du couvercle ou les réparations de l'appareil devront être confiés exclusivement à un technicien d'entretien qualifié.

- The name plate is located on the bottom of the unit.

- La plaquette signalétique est placée sur le panneau de fond de l'appareil.

**LASER SAFETY**

This unit employs a laser. Due to possible eye injury, only a qualified service person should remove the cover or attempt to service this device.

**DANGER**

This unit emits visible laser radiation when open. Avoid direct eye exposure to beam. When this unit is plugged into a wall outlet, do not place your eyes close to the opening of the disc tray and other openings or look inside.

**DANGER**

Risque d'exposition au laser en cas d'ouverture. Eviter toute exposition au faisceau. Lorsque cet appareil est branché à la prise de courant, ne pas approcher les yeux de l'ouverture du plateau changeur et des autres ouvertures pour regarder à l'intérieur.

**LASER**

Type	Laser à semi-conducteur GaAIAs
Longueur d'onde	650 nm (DVD) 784 nm (VCD/CD)
Puissance de sortie	7 mW (DVD/VCD/CD)
Divergence de faisceau	60 degrés

**LASER**

Type	Semiconductor laser GaAIAs
Wave length	650 nm (DVD) 784 nm (VCD/CD)
Output Power	7 mW (DVD/VCD/CD)
Beam divergence	60 degrees

**AVERTISSEMENT**

L'utilisation de commandes et l'emploi de réglages ou de méthodes autres que ceux décrits ci-dessous, peuvent entraîner une exposition à un rayonnement dangereux.

# CAUTION: READ THIS BEFORE OPERATING YOUR UNIT.

- 1 To assure the finest performance, please read this manual carefully. Keep it in a safe place for future reference.
- 2 Install this sound system in a well ventilated, cool, dry, clean place with at least 10 cm on the top, 10 cm on the left and right, and 10 cm at the back of DVR-S300 and at least 1 m above, 30 cm behind and on both sides of NX-SW300 or NX-SW301 for adequate ventilation. — away from direct sunlight, heat sources, vibration, dust, moisture, and/or cold.
- 3 Locate this unit away from other electrical appliances, motors, or transformers to avoid humming sounds.
- 4 Do not expose this unit to sudden temperature changes from cold to hot, nor locate this unit in an environment with high humidity (i.e., a room with a humidifier) to prevent condensation inside this unit, which may cause an electrical shock, fire, damage to this unit, and/or personal injury.
- 5 Avoid installing this unit in a location where foreign objects may fall onto this unit or where this unit may be exposed to liquid dripping or splashing. On the top of this unit, do not place:
  - Other components, as they may cause damage and/or discoloration on the surface of this unit.
  - Burning objects (i.e., candles), as they may cause fire, damage to this unit, and/or personal injury.
  - Containers with liquid in them, as they may fall, spilling the liquid and causing an electrical shock to the user and/or damage to this unit.
- 6 Do not cover this unit with a newspaper, tablecloth, curtain, etc. in order not to obstruct heat radiation. If the temperature inside this unit rises, it may cause fire, damage to this unit, and/or personal injury.
- 7 Do not plug in this unit to a wall outlet until all connections are complete.
- 8 Do not operate this unit upside-down. It may overheat, possibly causing damage.
- 9 Do not use excessive force on switches, knobs and/or cords.
- 10 When disconnecting the power cord from the wall outlet, grasp the plug; do not pull the cord.
- 11 Do not clean this unit with chemical solvents; this might damage the finish. Use a clean, dry cloth.
- 12 Use only the voltage specified on this unit. Using this unit with a higher voltage than specified is dangerous and may cause fire, damage to this unit, and/or personal injury. YAMAHA will not be held responsible for any damage resulting from use of this unit with a voltage other than as specified.
- 13 To prevent damage by lightning, keep the power cord out and outdoor antennas disconnected from a wall outlet or the unit during a lightning storm.
- 14 Do not attempt to modify or fix this unit. Contact qualified YAMAHA service personnel when any service is needed. The cabinet should never be opened for any reason.
- 15 When not planning to use this unit for long periods of time (i.e., vacation), disconnect the AC power plug from the wall outlet.
- 16 Be sure to read the “TROUBLESHOOTING” section on common operating errors before concluding that this unit is faulty.
- 17 Before moving this unit, press STANDBY/ON to set the unit in standby mode, then disconnect the AC power plug from the wall outlet.
- 18 Condensation will form when the surrounding temperature changes suddenly. Disconnect the power cable from the outlet, then leave the unit alone.
- 19 When using the unit for a long time, the unit may become warm. Turn the power off, then leave the unit alone for cooling.
- 20 Install this unit near the AC outlet and where the AC power plug can be reached easily.

## FOR CANADIAN CUSTOMERS

To prevent electric shock, match wide blade of plug to wide slot and fully insert.

This Class B digital apparatus complies with Canadian ICES-003.

This unit is not disconnected from the AC power source as long as it is connected to the wall outlet, even if this unit itself is turned off. This state is called the standby mode. In this state, this unit is designed to consume a very small quantity of power.

Laser component in this product is capable of emitting radiation exceeding the limit for Class 1.

## WARNING

TO REDUCE THE RISK OF FIRE OR ELECTRIC SHOCK, DO NOT EXPOSE THIS UNIT TO RAIN OR MOISTURE.

## CAUTION

Danger of explosion if battery is incorrectly replaced. Replace only with the same or equivalent type.

# CONTENTS

1

## 1. INTRODUCTION

<b>INTRODUCTION</b> .....	<b>2</b>
Supplied accessories .....	5
<b>FUNCTIONAL OVERVIEW</b> .....	<b>6</b>
Top and front panels (DVR-S300) .....	6
Rear panel (DVR-S300) .....	7
Rear panel (NX-SW300) .....	8
Rear panel (NX-SW301) .....	8
Remote control (For DVR-S300) .....	9

## 2. PREPARATION

<b>CONNECTIONS</b> .....	<b>11</b>
Roles and layout of the speakers .....	11
Placing the center speaker .....	12
Placing the front/surround speakers .....	13
Placing the subwoofer .....	13
<b>SYSTEM CONNECTIONS</b> .....	<b>14</b>
Connecting the speakers (DVX-S301) .....	14
Connecting the speakers (DVX-S302) .....	15
Connecting the speakers (DVX-S303) .....	16
Connecting the speaker cables .....	17
Connecting the subwoofer .....	17
Connecting the DVD receiver and the subwoofer .....	18
<b>OTHER CONNECTIONS</b> .....	<b>19</b>
Connecting a TV .....	19
Connecting the FM/AM antennas .....	20
Connecting external AV components .....	21
Connecting digital audio components .....	22

## 3. BASIC OPERATION

<b>GETTING STARTED</b> .....	<b>23</b>
Inserting batteries into the remote control ....	23
Using the remote control .....	23
Setting a TV .....	24
Setting language preferences .....	26
Setting speaker channels .....	27

## 4. OPERATIONS

<b>DISC OPERATION</b> .....	<b>28</b>
Playing discs .....	28
Basic playback controls .....	28
Selecting various repeat shuffle functions .....	29
Shuffle .....	29
Other operations for video playback (DVD/VCD/SVCD) .....	30
Playing MP3/JPEG/DivX® discs .....	33
Playing Super Audio CDs .....	34
Special features for picture disc playback .....	35

## 5. ON-SCREEN MENU

<b>DVD SETUP MENU OPTIONS</b> .....	<b>36</b>
General setup menu .....	36
Audio setup menu .....	38
Video setup menu .....	39
Preference setup menu .....	41

## 6. OTHER FEATURES

<b>TUNER OPERATIONS</b> .....	<b>44</b>
Tuning radio stations .....	44
Presetting radio stations .....	44
<b>SOUND CONTROLS</b> .....	<b>46</b>
Selecting surround sound .....	46
Selecting digital sound effects .....	46
Adjusting the treble/bass level .....	46
Adjusting the volume level .....	47
Night listening mode .....	47
Switching to active mode .....	47
Switching to standby mode .....	47
<b>OTHER FUNCTIONS</b> .....	<b>48</b>
Setting remote control codes .....	48
Controlling other components .....	48
Dimming the display screen .....	49
Setting the sleep timer .....	49
Recording on an external AV component ....	49
<b>TROUBLESHOOTING</b> .....	<b>50</b>
<b>GLOSSARY</b> .....	<b>52</b>
<b>SPECIFICATIONS</b> .....	<b>54</b>

2

3

4

5

6

# INTRODUCTION

Thank you for purchasing this unit. This Owner's Manual explains the basic operation of this unit.

## Notes about discs

- This receiver is designed for use with the following discs: Super Audio CD (Super Audio CD), DVD-Video, Video CD, Super Video CD, Audio CD, CD-R, CD-RW, DVD-Audio, DVD+RW, DVD+R, DVD-R, DVD-RW and DVD-RW (VR format).

This receiver can play:

- MP3 and picture (Kodak, JPEG) files recorded on CD-R(W).
- JPEG/ISO 9660 format
- Maximum 30 character display
- DivX® disc on CD-R[W]/DVD+R[W]/DVD-R[W](3.11, 4.x and 5.x)

## Notes

- CD-R, CD-RW and DVD-RW (VR format) cannot be played unless finalized.
- Some discs cannot be played depending on the recording conditions, such as the PC environment and application software. The characteristics and condition of some discs; materials, scratches, curvature, etc. may result in playback failure.
- Be sure to use only CD-R and CD-RW discs made by reliable manufacturers.
- Do not use any non-standard shaped discs (heart-shaped, etc.).
- Do not use discs with tape, seals, or paste on their surface. Doing so may damage this receiver.
- Do not use discs affixed with labels printed by a commercially available label printer.

## Cleaning discs

- When a disc becomes dirty, clean it with a cleaning cloth. Wipe the disc from the center out. Do not wipe in a circular motion.
- Do not use solvents such as benzine, thinner, commercially available cleaners, or antistatic spray intended for analog records.

## Avoid high temperatures, moisture, water and dust

- Do not expose the system, batteries or discs to humidity, rain, sand or excessive heat (caused by heating equipment or direct sunlight). Always keep the disc tray closed to avoid getting dust on the lens.

## Avoid condensation problem

- The lens may cloud over when the receiver is suddenly moved from cold to warm surroundings, making it impossible to play a disc. Leave the receiver in the warm environment until the moisture evaporates.

## Disc care

- Write only on the printed side of a CD-R/CD-RW and only with a soft felt-tipped pen.
- Handle the disc by its edge; do not touch the surface.

## Cabinet care













- Use a soft cloth slightly moistened with a mild detergent solution. Do not use a solution containing alcohol, spirits, ammonia, or abrasives.

## Choosing a suitable location

- Place the receiver on a flat, hard, and stable surface.

## Region codes

The unit is designed to support the Region Management System. Check the region code number on the disc package. If the number does not match the unit's region number (see the table below or the back of the unit), the unit may be unable to play the disc.

Destination	Region code of DVR-S300	Playable discs
U.S.A. and Canada models		 
U.K. and Europe models		 
Australia model		 
Korea, Asia and Taiwan models		 

## Sound field features



Manufactured under license from Dolby Laboratories. "Dolby", "Pro Logic", "MLP Lossless" and the double-D symbol are trademarks of Dolby Laboratories.



"DTS" and "DTS Digital Surround" are registered trademarks of Digital Theater Systems, Inc.



"DivX", "DivX Certified", and associated logos are trademarks of DivXNetworks, Inc and are used under license.



This product incorporates copyright protection technology that is protected by method claims of certain U.S. patents and other intellectual property rights owned by Macrovision Corporation and other rights owners. Use of this copyright protection technology must be authorized by Macrovision Corporation, and is intended for home and other limited viewing uses only unless otherwise authorized by Macrovision Corporation. Reverse engineering or disassembly is prohibited.



Active Servo Processing Subwoofer System with built-in power amplifier.

This subwoofer system (NX-SW300, NX-SW301) employs Advanced YAMAHA Active Servo Technology which YAMAHA has developed for reproducing higher quality super-bass sound. This super-bass sound adds a more realistic, theater-in-the-home effect to your stereo system.

## ■ We Want You Listening For A Lifetime

YAMAHA and the Electronic Industries Association's Consumer Electronics Group want you to get the most out of your equipment by playing it at a safe level. One that lets the sound come through loud and clear without annoying blaring or distortion - and, most importantly, without affecting your sensitive hearing. Since hearing damage from loud sounds is often undetectable until it is too late, YAMAHA and the Electronic Industries Association's Consumer Electronics Group recommend you to avoid prolonged exposure from excessive volume levels.





**DVX-S301**

DVD receiver  
(DVR-S300)



Subwoofer  
(NX-SW301)

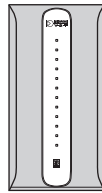

Center speaker  
(NX-C301)

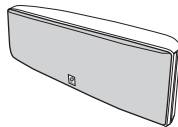

Front/Surround  
speakers (x4)  
(NX-S301)

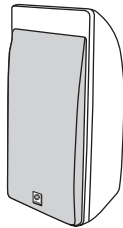

**DVX-S302**

DVD receiver  
(DVR-S300)

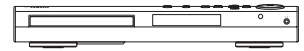

Subwoofer  
(NX-SW301)

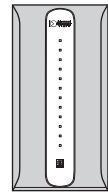

Center speaker  
(NX-C302)

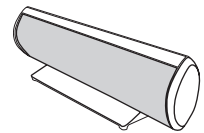

Front/Surround  
speakers (x4)  
(NX-S302)

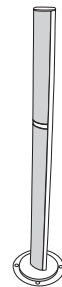

**DVX-S303**

DVD receiver  
(DVR-S300)



Subwoofer  
(NX-SW300)

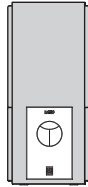

Center speaker  
(NX-C302)

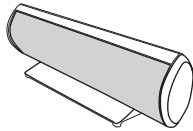

Front/Surround  
speakers (x 4)  
(NX-S302)

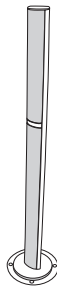

## ■ Supplied accessories

FM wire antenna



AM loop antenna



Remote control



Batteries (x 2)



Video pin cable



System control cable  
(4 m)

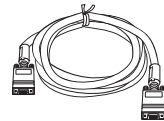

Speaker cables  
(5 m x 3)  
(15 m x 2)

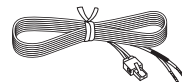
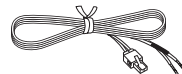

Fasteners (2 sets)



Base(x 4)  
(For NX-S302)



Screws (x 8)  
Washers (x 8)  
(For NX-S302)



Non-skid pad (1 set)  
(For NX-SW301)



# FUNCTIONAL OVERVIEW

## ■ Top and front panels (DVR-S300)

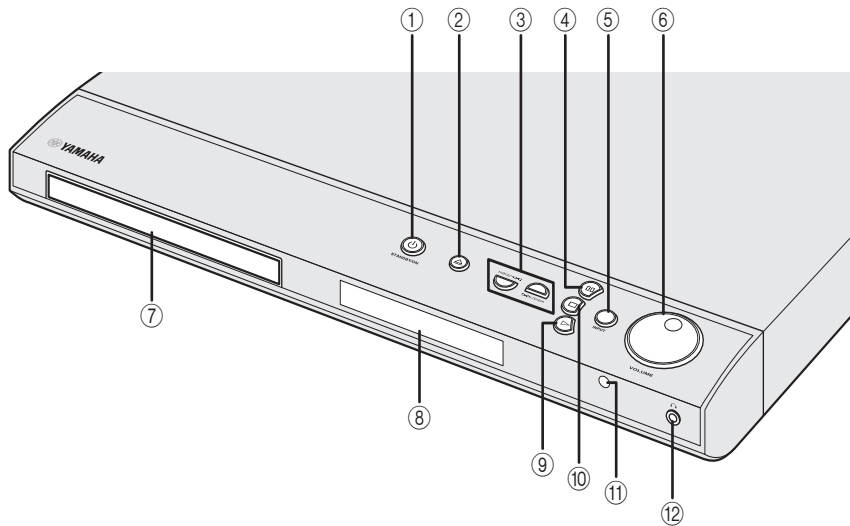

### ① **STANDBY/ON**

Turns on the DVD receiver, or sets it to the standby mode (see “Auto eco power standby mode” on page 28).

### ②

Opens/closes the disc tray.

### ③

DVD/CD mode: selects the previous/next track or chapter. Press and hold to fast forward or fast reverse.  
TUNER mode: tunes the radio preset up/down.

### ④

DVD/CD mode: pauses disc playback.

### ⑤ **INPUT**

Selects an input source or sets the priority level for the audio input signals.

### ⑥ **VOLUME**

Adjusts the volume level.

### ⑦ **Disc tray**

Load the disc in the disc tray.

### ⑧ **System display panel**

Shows information about the operational status of the unit.

**MULTI**

Lights up when you play a multi-channel audio source.

**DOWNMIX**

Lights up when you play discs that allow down mixing of multi-channel audio sources.

It does not light up for discs that prohibit down mixing, even if you play a multi-channel audio source.

### ⑨

DVD/CD mode: starts disc playback.

TUNER mode: starts preset radio station installation in Plug & Play mode.

### ⑩

Exits an operation.

DVD/CD mode: stops playback.

TUNER mode: erases a preset radio station in Preset mode if held more than two seconds, or stops preset radio station installation in Auto Preset mode.

### ⑪ **Remote control sensor**

Point the remote control towards this sensor.

### ⑫ **Head phone jack**

Connects headphones.

## ■ Rear panel (DVR-S300)

(U.K. and Europe models)

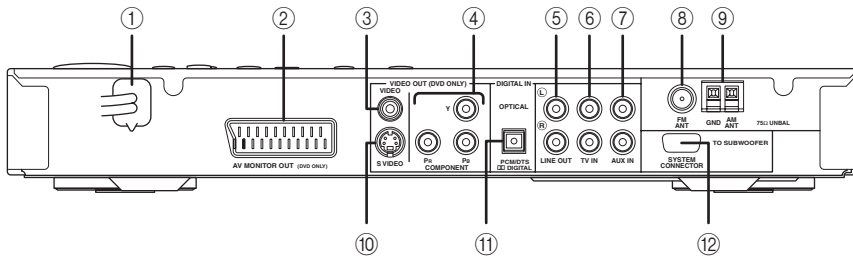

- ① **AC power cord**  
Connect to a standard AC outlet.
- ② **AV MONITOR OUT terminal (U.K. and Europe models only)**  
Connect to your TV (see page 19).
- ③ **VIDEO output terminal**  
Connect to the video (composite) jack on your TV (see page 19).
- ④ **COMPONENT VIDEO OUT terminal**  
Connect the the Y PB/CB PR/CR jacks on your TV (see page 19).
- ⑤ **LINE OUT terminal**  
Connect to the AUDIO IN jacks on your VCR.
- ⑥ **TV IN terminal**  
Connect to the corresponding AUDIO OUT jacks on your TV (see page 19).
- ⑦ **AUX IN terminal**  
Connect to the AUDIO OUT jacks on your VCR or cassette deck.
- ⑧ **FM ANT terminal**  
Connect the FM antenna.
- ⑨ **GND and AM ANT terminals**  
Connect the AM loop antenna.
- ⑩ **S VIDEO output terminal**  
Connect to the S-video jack on your TV or VCR.
- ⑪ **OPTICAL DIGITAL IN terminal**  
Connect to the DIGITAL OUT jack on your digital audio component.
- ⑫ **SYSTEM CONNECTOR terminal**  
Connect the subwoofer.

■ Rear panel (NX-SW300)

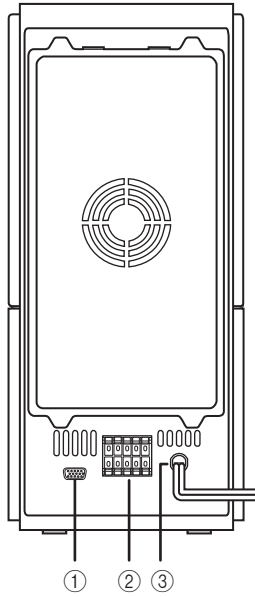

- ① **SYSTEM CONNECTOR terminal**  
Connect to the DVD receiver.
- ② **SPEAKER terminals**  
Connect to the speakers.
- ③ **AC power cord**  
Connect to a standard AC outlet.

■ Rear panel (NX-SW301)

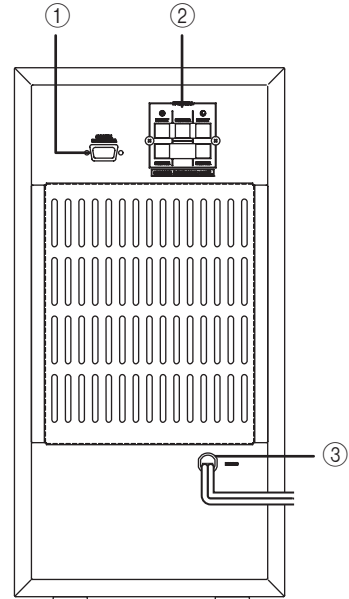

- ① **SYSTEM CONNECTOR terminal**  
Connect to the DVD receiver.
- ② **SPEAKER terminals**  
Connect to the speakers.
- ③ **AC power cord**  
Connect to a standard AC outlet.

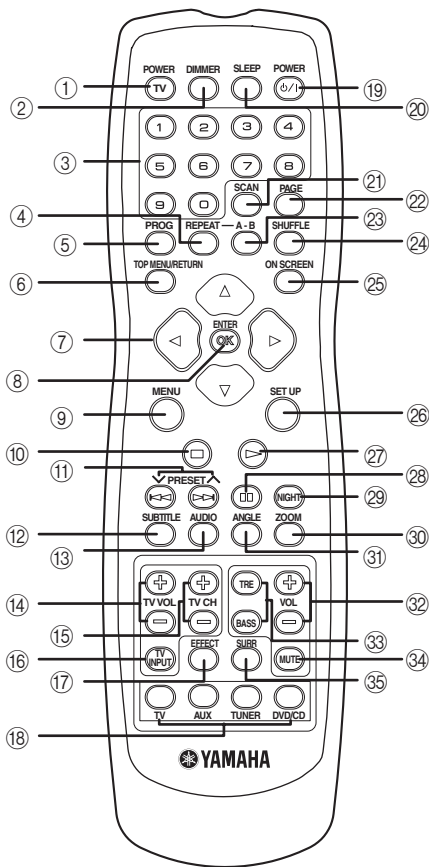

## Remote control (For DVR-S300)



### Note

For details on how to use the remote control, see page 23.

- ① **POWER (TV)**  
Turns on the TV, or sets it to the standby mode.
- ② **DIMMER**  
Selects different levels of brightness for the display panel.
- ③ **Numeric keypad (0 – 9)**  
Enters a track/title number of the disc.  
Enters a number of a preset radio station.
- ④ **REPEAT**  
Selects various repeat modes.
- ⑤ **PROG**  
DVD/CD mode: starts programming.  
TUNER mode: starts automatic/manual preset programming if held for more than two seconds.
- ⑥ **TOP MENU/RETURN**  
Returns to the previous menu.  
Displays the top-level disc menu (if available).
- ⑦ **Cursors (◀ / ▶ / ▲ / ▼)**  
Selects movement direction in the menu.  
TUNER mode: press left or right to tune the radio frequency.  
TUNER mode: press up or down to select auto tuning.
- ⑧ **ENTER (OK)**  
Confirms a selection.
- ⑨ **MENU**  
Enters or exits the disc contents menu.  
For VCD version 2.0 only:  
In stop mode, turns on/off playback control (PBC) mode.  
During playback, returns to the main menu.
- ⑩ **□**  
Exits an operation.  
DVD/CD mode: stops playback.  
DVD/CD mode: holding down the button will open and close the disc tray.  
TUNER mode: erases a preset radio station if held for more than two seconds.
- ⑪ **PRESET ^ (◀◀ / ▶▶)**  
DVD/CD mode: selects the previous/next track or chapter. Press and hold to fast forward or fast reverse.  
TUNER mode: press to select a preset radio station.
- ⑫ **SUBTITLE**  
Selects a subtitle language.

- ⑬ **AUDIO**  
Selects an audio language (DVD) or an audio channel (VCD).
- ⑭ **TV VOL (+ / -)**  
Adjusts the TV volume.
- ⑮ **TV CH (+ / -)**  
Switches the TV channel.
- ⑯ **TV INPUT**  
Switches the TV input.
- ⑰ **EFFECT**  
Selects a sound effect.
- ⑱ **Input selection buttons**  
Selects the appropriate active source mode.  
TV mode: switches to TV input.  
AUX mode: switches to AUX ANALOG/AUX DIGITAL input.  
TUNER mode: switches tuner (FM/AM) input.  
DVD/CD mode: switches to DVD/CD mode.
- ⑲ **POWER (  / I )**  
Turns on the DVD receiver, or sets it to the standby mode.
- ⑳ **SLEEP**  
Sets the sleep timer.
- ㉑ **SCAN**  
Scans each track/chapter on the disc.
- ㉒ **PAGE**  
Turns the pages of DVD-Audio still pictures.
- ㉓ **REPEAT A-B**  
Repeats a specific section on a disc.
- ㉔ **SHUFFLE**  
Plays tracks in random order.
- ㉕ **ON SCREEN**  
Displays the current status or disc information.
- ㉖ **SET UP**  
Enters or exits the system setup menu.
- ㉗    
DVD/CD mode: starts disc playback.
- ㉘    
DVD/CD mode: pauses disc playback.
- ㉙ **NIGHT**  
Turns the Night mode on or off.
- ㉚ **ZOOM**  
Enlarges or reduces the TV screen picture.
- ㉛ **ANGLE**  
Selects a DVD disc camera angle (if available).
- ㉜ **VOL (+ / -)**  
Adjusts the volume level.
- ㉝ **TRE/BASS**  
Selects the TREBLE (high tone) or BASS (low tone) sound mode.  
Use the VOLUME control to change the tone level.
- ㉞ **MUTE**  
Mutes or restores the volume.
- ㉟ **SURR**  
Selects multi-channel surround or stereo mode.

# CONNECTIONS

## 2

### PREPARATION

#### ■ Roles and layout of the speakers

To enjoy quality sounds you need to place the speakers in their appropriate positions and install them correctly. The following show the recommended layout of the speakers.

#### DVX-S301

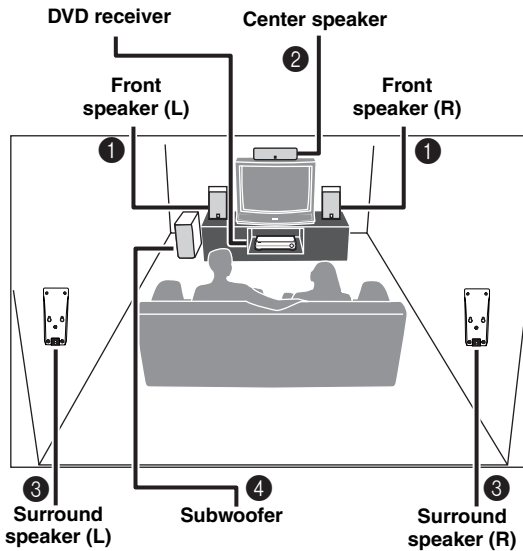

#### DVX-S302/DVX-S303

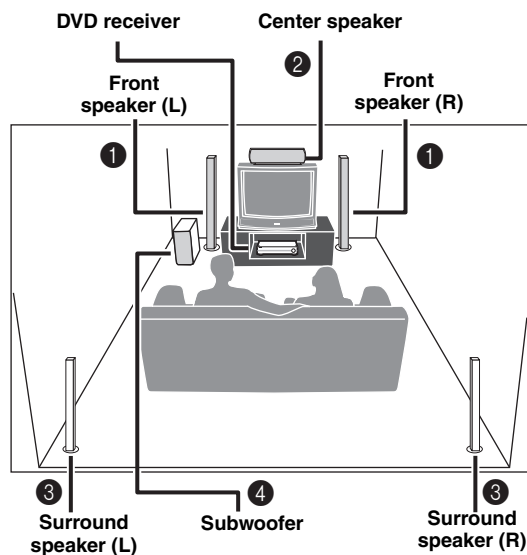

For the best possible surround sound, all of the speakers (except the subwoofer) should be placed at the same distance from the listening position.

#### ① Front Speakers (L, R)

Place the front left/right speakers on both sides of your TV at equal distances.

Main roles: Produces front channel (stereo) sounds and effect sounds.

#### ② Center Speaker

Place on top of the TV or inside the TV rack so that the speaker and TV are aligned vertically.

Main role: Produces sounds oriented toward the center of the screen such as dialogues or vocal sounds.

#### ③ Surround Speakers (L, R)

Place the surround left/right speakers behind the listening position. (For NX-S301, we recommend placing them at a height of 1.8 m (6 feet) and pointing them at the listening position.)

Main roles: Produces surround sounds and effect sounds.

#### ④ Subwoofer

Place the subwoofer near a front speaker and turn it slightly toward the center of the room to reduce wall reflections.

Main roles: Produces bass sounds and low frequency (LFE) sounds contained in Dolby Digital or DTS.

#### Note

To avoid magnetic interference, do not position the front speakers too close to your TV.

Allow adequate ventilation around the DVD receiver and subwoofer.

Bass sounds produced by the subwoofer may be heard differently depending on the listening position and subwoofer location.

To enjoy desired sounds, try to change the location of the subwoofer according to the listening position.



## ■ Placing the center speaker

When placing the center speaker on top of the TV, use the supplied fasteners to secure the speaker.

### NX-C301

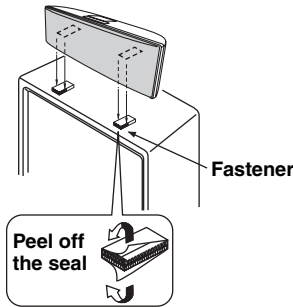

### NX-C302

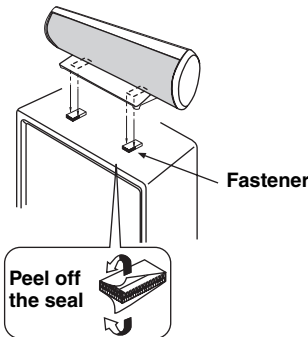

- ① Peel off the seals on one side of the fasteners and attach them to the bottom of the center speaker.
- ② Peel off the seals on the other side of the fasteners and attach them to the top of the TV.

### Notes

- Do not place the speaker on the TV if the top of the TV is uneven or narrower than the bottom surface of the speaker. Doing so may cause the speaker to fall. In this case, place the speaker inside a TV rack or on a level floor.
- Before attaching the fasteners to the TV, clean the surface with a dry cloth. A dirty or wet surface may weaken the adhesive force and cause the speaker to fall.
- Do not touch the bonding surfaces of the fasteners after peeling off the seals. Doing so may weaken the adhesive force and cause the speaker to fall. this installation. Use metric screw threads only.

## Attaching to a wall

You can attach the speakers to a wall using commercially available screws (Diameter: 3.5 to 4 mm, Length: 25 mm or more). Each speaker requires two screws.

### NX-C301

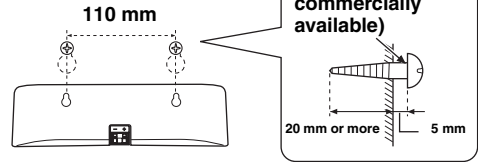

### NX-C302

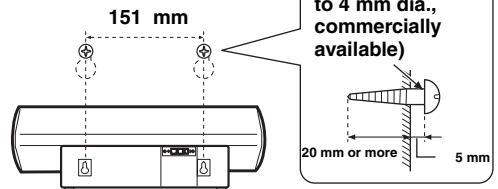

- ① Install two screws in the wall where you want to place the speaker.
- ② Hang the speaker on the screws using the holes in the back of the speaker.

### Notes

- To attach a speaker to a wall using screws, the wall must be firm. Do not attach a speaker to a wall that is made of weak materials such as plaster or veneered woods. Doing so may cause the speaker to fall.
- When connecting the speakers, fix the speaker cables in place so that cables do not loosen. If your foot or hand accidentally gets caught on a loose speaker cable, the speaker may fall.
- After attaching each speaker, check that the speaker is fixed securely. YAMAHA will bear no responsibility for any accidents caused by improper installations.

## ■ Placing the front/surround speakers

### Attaching to a wall

You can attach the speakers to a wall using commercially available screws (Diameter: 3.5 to 4 mm, Length: 25 mm or more). Each speaker requires two screws.

#### NX-S301

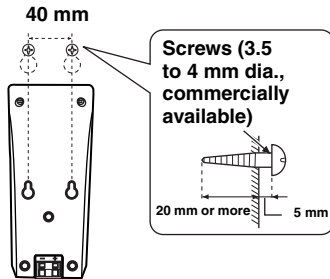

- ① Install two screws in the wall where you want to place the speaker.
- ② Hang the speaker on the screws using the holes in the back of the speaker.

#### Notes

- To attach a speaker to a wall using screws, the wall must be firm. Do not attach a speaker to a wall that is made of weak materials such as plaster or veneered woods. Doing so may cause the speaker to fall.
- When connecting the speakers, fix the speaker cables in place so that cables do not loosen. If your foot or hand accidentally gets caught on a loose speaker cable, the speaker may fall.
- After attaching each speaker, check that the speaker is fixed securely. YAMAHA will bear no responsibility for any accidents caused by improper installations.

### ■ Hanging on a wall (NX-S301)

You can hang the speakers on a wall using a commercially available bracket and screws (Diameter: 6 mm). Attach a bracket firmly to the rear of the speakers using screws. Then mount a screw on the wall where the speaker is to be hung and hook the speaker securely onto the mounted screws.

#### Note

Do not use screw threads measured in inches for this installation. Use metric screw threads only.

### ■ Attaching the base

Attach the base to the bottom of the front/surround speakers (NX-S302) with the supplied base mounting screws as shown below.

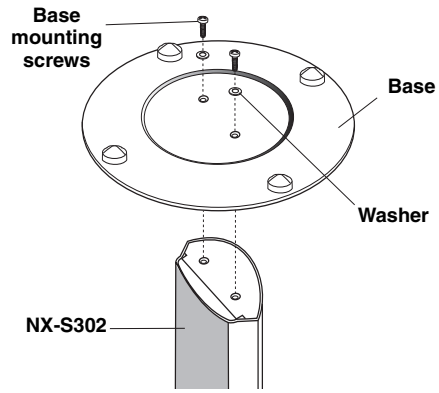

#### Note

Placing the speakers (NX-S302) on the places such as hard wooden floor may scratch the surface of the floor.

### ■ Placing the subwoofer

Attach the non-skid pads to the bottom of the subwoofer (NX-SW301), and then place the subwoofer on a level hard floor.

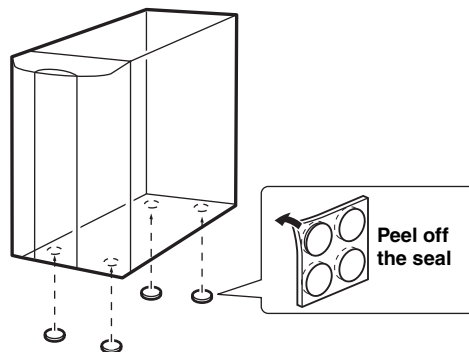

#### Note

Using non-skid pads prevents the subwoofer from sliding when it vibrates, and ensure quality sound production.

# SYSTEM CONNECTIONS

## ■ Connecting the speakers (DVX-S301)

### Notes

- Do not connect the power cord of the subwoofer and DVD receiver into an AC outlet until all cable connections are completed.
- Please refer to the pages below for detailed information on how connect each speaker.

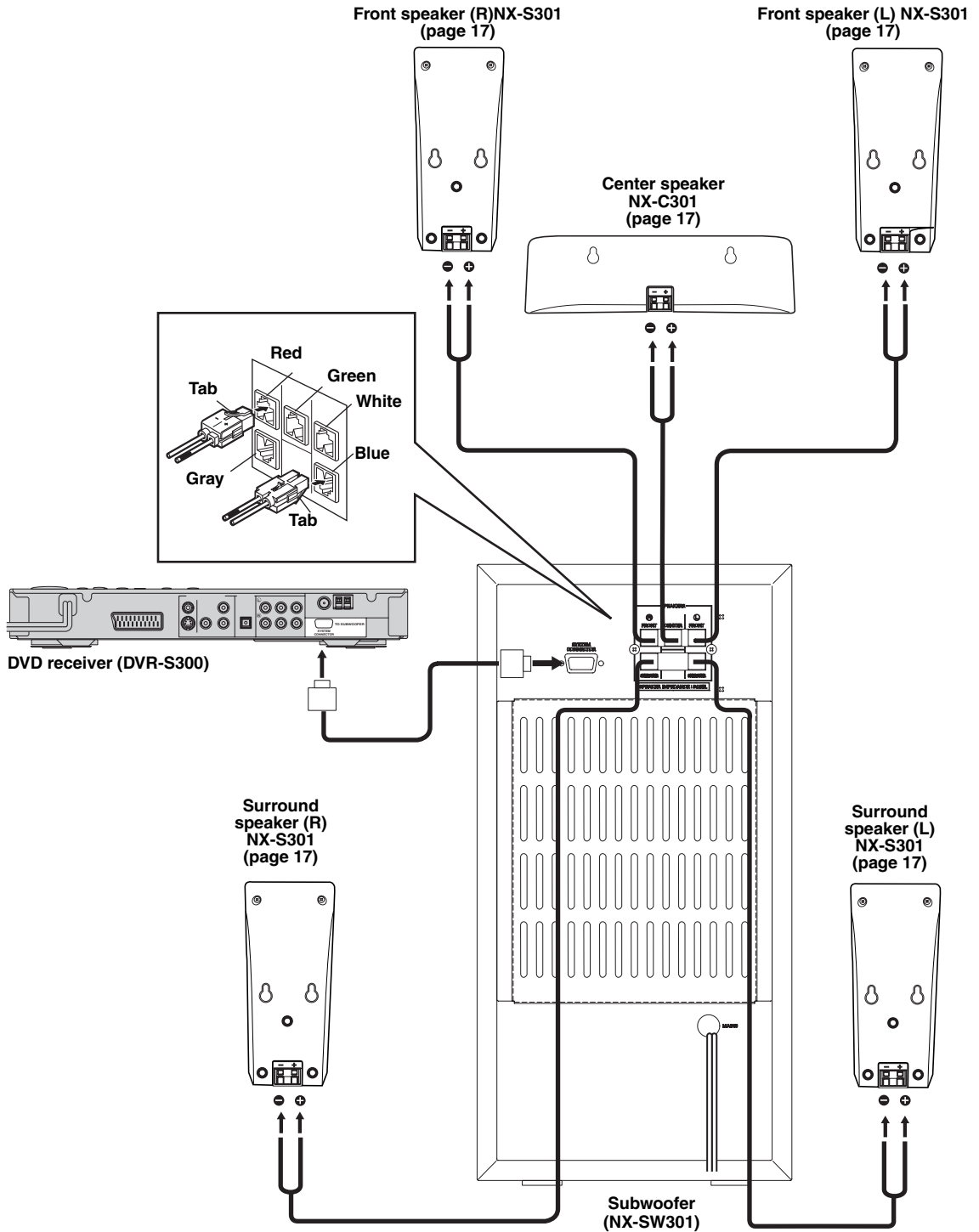

## ■ Connecting the speakers (DVX-S302)

### Notes

- Do not connect the power cord of the subwoofer and DVD receiver into an AC outlet until all cable connections are completed.
- Please refer to the pages below for detailed information on how connect each speaker.

2

PREPARATION

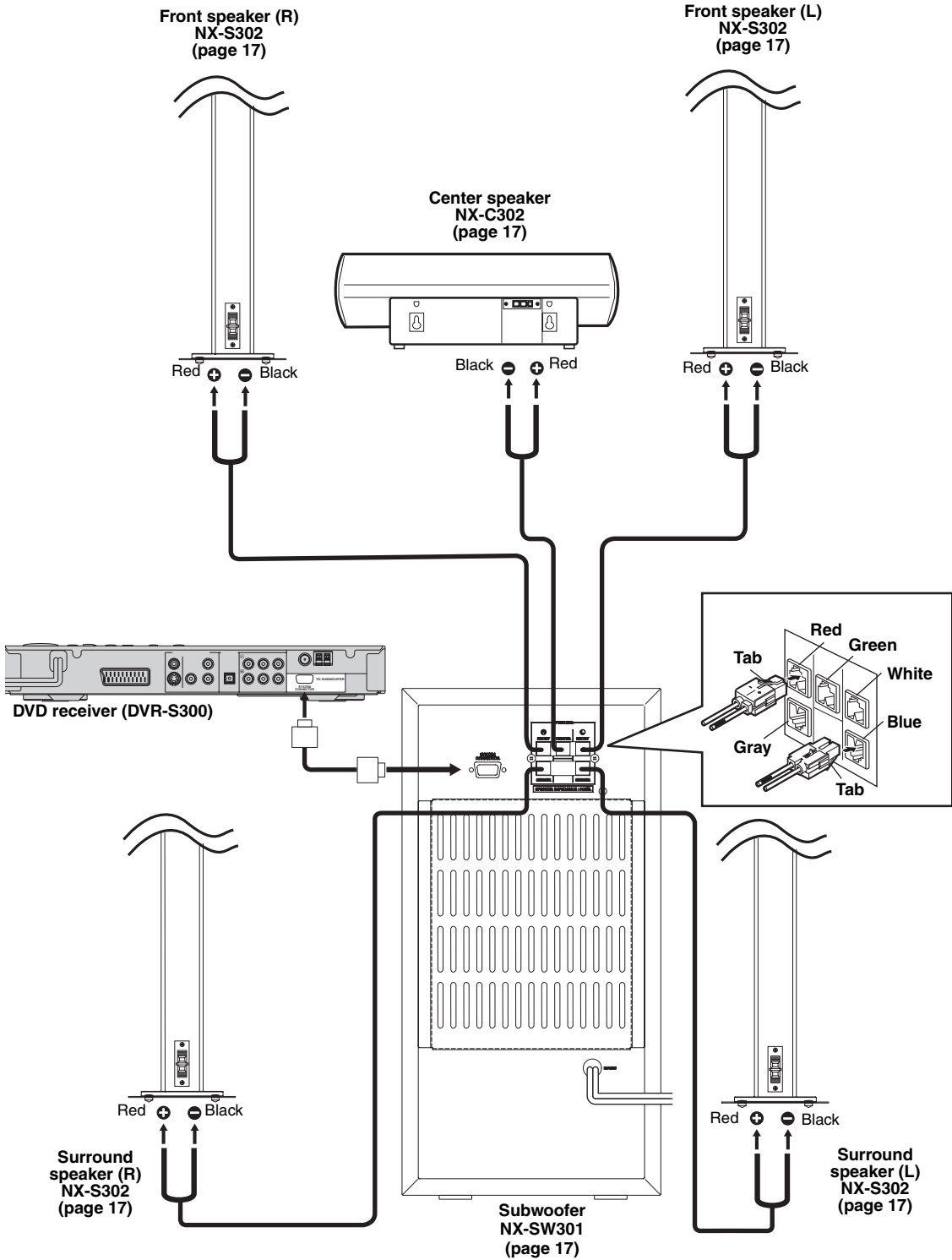

English

## ■ Connecting the speakers (DVX-S303)

### Notes

- Do not connect the power cord of the subwoofer and DVD receiver into an AC outlet until all cable connections are completed.
- Please refer to the pages below for detailed information on how to connect each speaker.

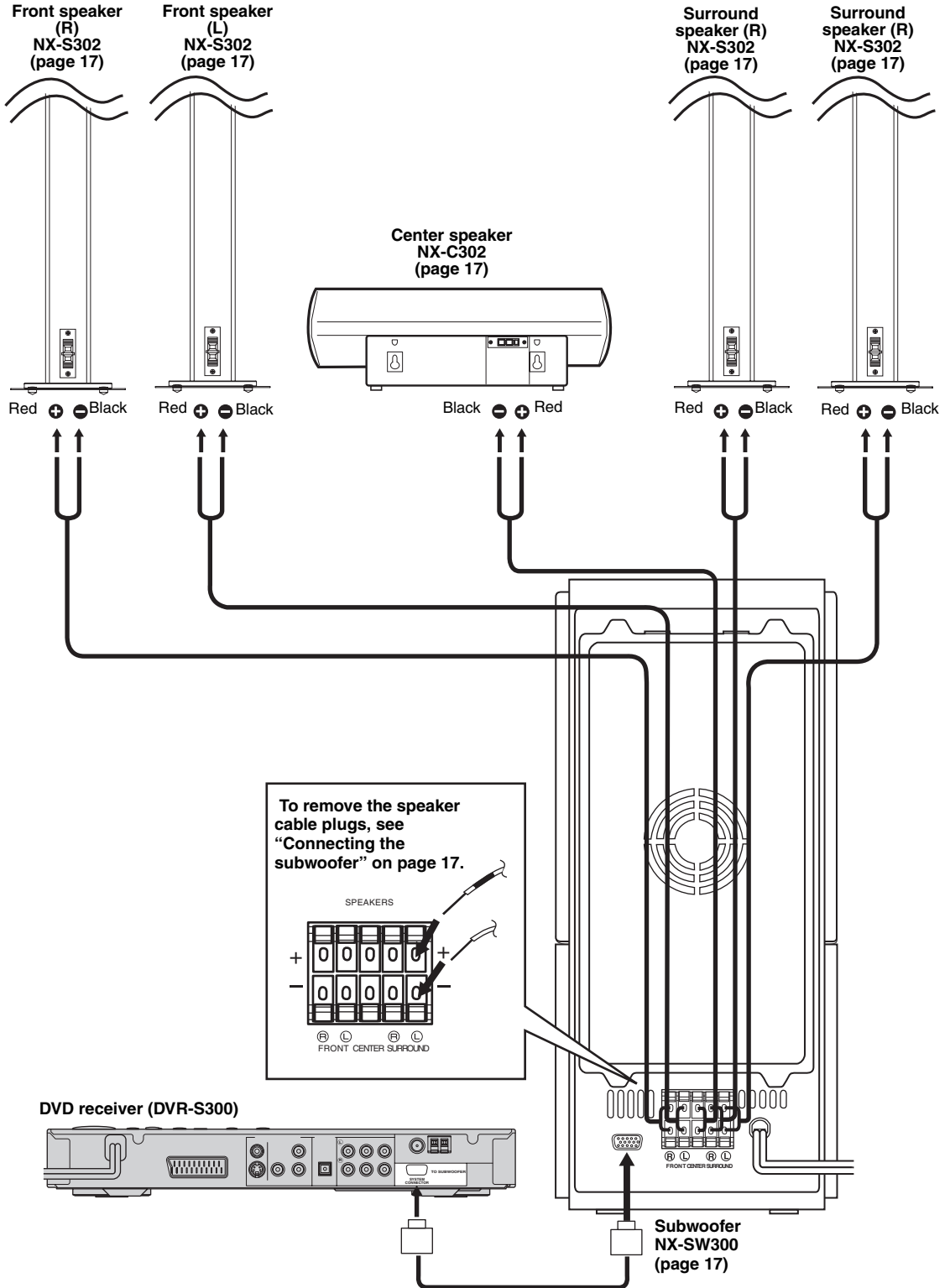

### ■ Connecting the speaker cables

Connect the speaker cable with the color band to the plus (Red +) connector on the front/center/surround speakers and with the white line to the minus (Black -) connector.

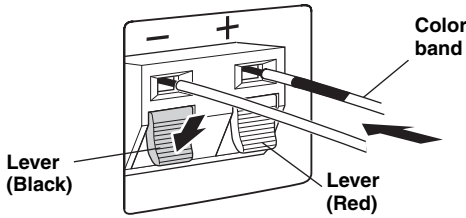

Press the lever down, then insert the cable into the hole and release the lever.

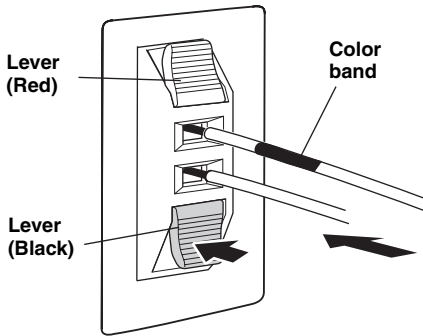

Press the lever down, then insert the cable into the hole and release the lever.

### ■ Connecting the subwoofer

Insert the cable plug of the speaker cable into the speaker jack of the same color until you hear it click into place.

- **FRONT R (Red), CENTER (Green), FRONT L (White):** Insert the cable plug facing the tub upwards.
- **SURROUND R (Gray), SURROUND L (Blue):** Insert the cable plug facing the tub downwards.

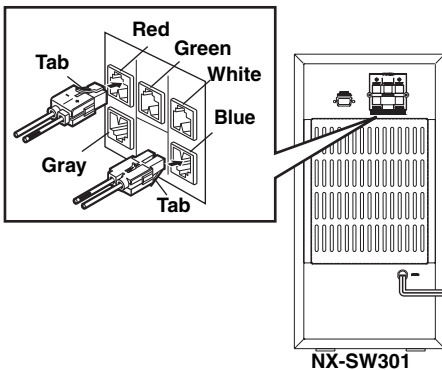

Before connecting the speaker cables to the subwoofer (NX-SW300), remove the cable plugs from supplied speaker cables. Press and hold the release button and remove the supplied speaker cable from the cable plug.

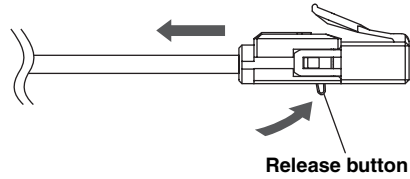

**Note**

Be sure to twist the cable core firmly in a clockwise direction. Twisting loosely may cause a short.

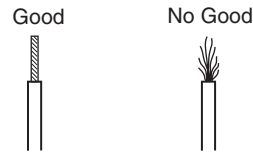

**FRONT R (Red), CENTER (Green), FRONT L (White):**  
**SURROUND R (Gray), SURROUND L (Blue):**

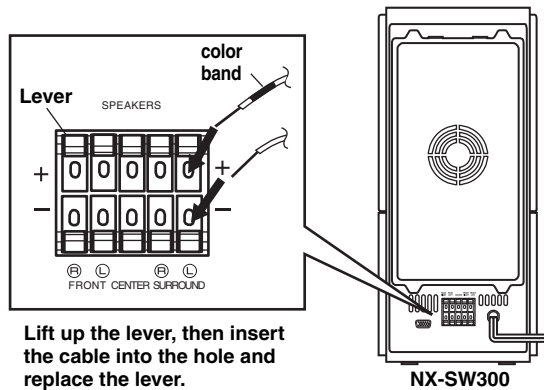

Lift up the lever, then insert the cable into the hole and replace the lever.

**Note**

Do not use excessive force when inserting the cable plug. Doing so may damage the cable plug or speaker jack.

## ■ Connecting the DVD receiver and the subwoofer

Connect the subwoofer to the DVD receiver using the system control cable. Attach one end of the subwoofer and the other to the **SYSTEM CONNECTOR** terminal at the rear of the DVD receiver.

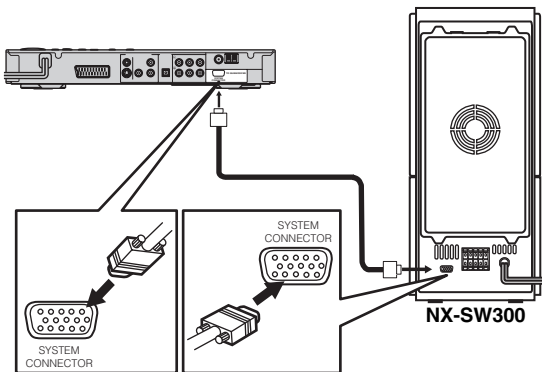
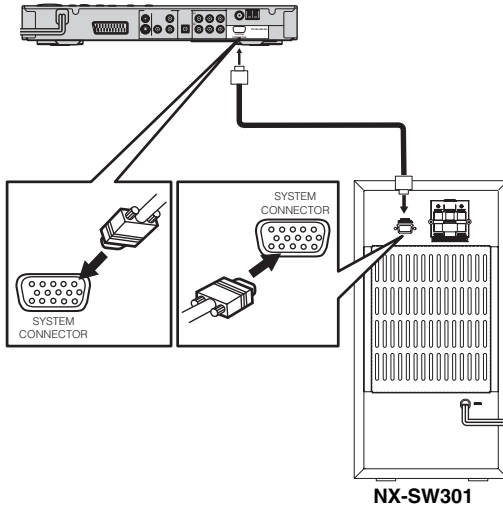

### Notes

- After inserting the system control cable, be sure to tighten the cable screws.
- Ensure that the speaker cables are correctly connected. Improper connections may damage the system due to a short-circuit.
- When connecting the speakers, fix the speaker cables in place so that cables do not loosen. If your foot or hand accidentally gets caught on a loose speaker cable, the speaker may fall.
- To prevent unwanted noise, do not place the subwoofer too close to the DVD receiver, AC power adaptor, TV or other sources of radiation.

# OTHER CONNECTIONS

## ■ Connecting a TV

### Notes

- You only need to make one video connection from the following options (A,B,C, or D), depending on the capabilities of your TV.
- Do not connect the power cords until all cable connections are completed.

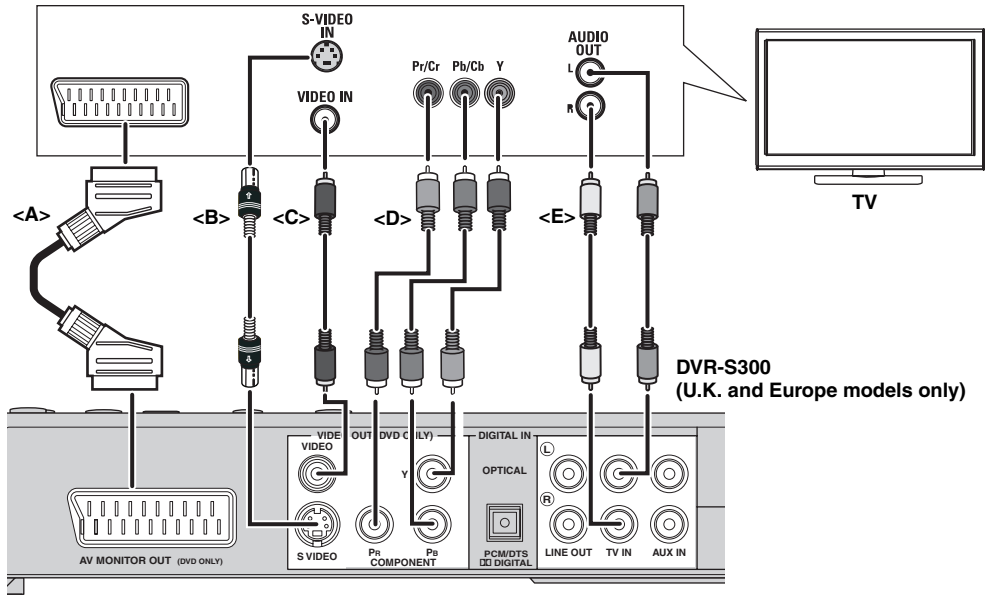

### AV MONITOR OUT terminal <A> (U.K. and Europe models only)

The SCART cable, or “Euro AV cable”, supports AV MONITOR OUT signal transmission, providing you with the best possible picture and sound. If your TV has only one terminal for video input, and you want to connect it directly to the DVD receiver, you can use the **AV MONITOR OUT** connector. Connect one end of the SCART cable to the **AV MONITOR OUT** connector and the other end to the SCART connector on your TV.

### Note

TV channels, if you use **AV MONITOR OUT** terminal to connect the TV. To use **AV MONITOR OUT** terminal, make sure to set the DVD receiver’s component setting to “**RGB**” (see page 25).

### S VIDEO output terminal<B>

S-(separate)video connections achieve a clearer picture than composite video connections. Use an S-video cable (not supplied) to connect the DVD receiver’s **S VIDEO** jack to the S-video input jack (or Y/C or S-VHS jack) on your TV.

### VIDEO output terminal <C>

Use a composite video cable (yellow -supplied) to connect the DVD receiver’s **VIDEO** jack to the video input jack (or A/V In/Video In/Composite/ Baseband jack) on your TV.

### COMPONENT VIDEO OUT terminals <D>

Use the component video cables (red/blue/green, not supplied) to connect the DVD receiver’s **Y Pb Pr** jacks to the corresponding component video input jacks (or the Y Pb/Cb Pr/Cr/ YUV jacks) on your TV. Progressive scan video quality is only available when using **Y Pb Pr** in conjunction with a progressive scan TV. To activate the progressive scan function see “Progressive function” on page 39.



## TV IN terminal <E>

To listen to TV channels through this DVD receiver, use the audio cables (white/red, not supplied) to connect the **TV IN** jacks to the corresponding audio out jacks on your TV.

### Notes

- When using **AV MONITOR OUT** terminal to listen to the TV channels, set the DVD receiver's component setting to "**RGB**" (see page 25).
- When using **TV IN** terminal, set the DVD receiver's component setting to "**YUV**" (see page 25).

## ■ Connecting the FM/AM antennas

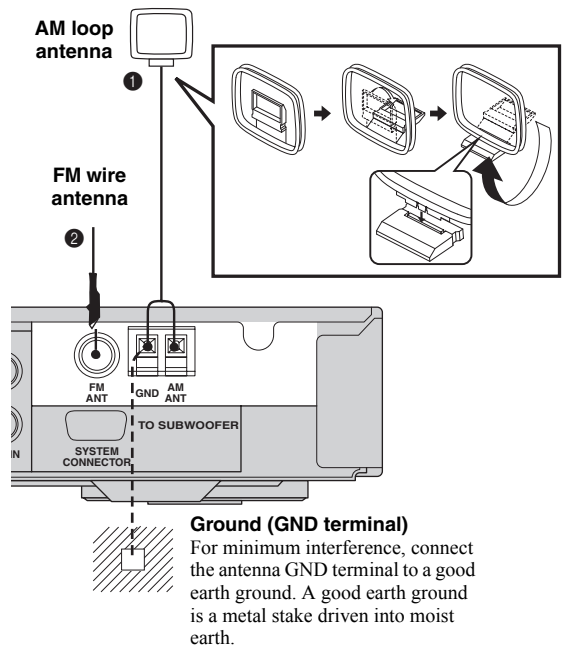

- 1 Connect the supplied AM loop antenna to the **AM ANT** terminal. Place the AM loop antenna on a shelf or attach it to a stand or wall.
- 2 Connect the supplied FM wire antenna to the **FM ANT** terminal. Extend the FM wire antenna and fix its ends to the wall.  
For better FM stereo reception, connect an external FM antenna (not supplied).

### Notes

- Adjust the position of the antennas for optimal reception.
- Position the antennas as far as possible from your TV, VCR or other sources of radiation to prevent unwanted interference.

## ■ Connecting external AV components

If you connect external AV equipment such as a VCR, cassette deck or digital audio component to the following AV jacks on the DVD receiver, you can enjoy those AV sources with the DVD receiver. Also, you can record AV sources played on the DVD receiver using the recording equipment. This section provides some examples of other AV equipment connections. For information on your AV equipment, refer to the manual provided.

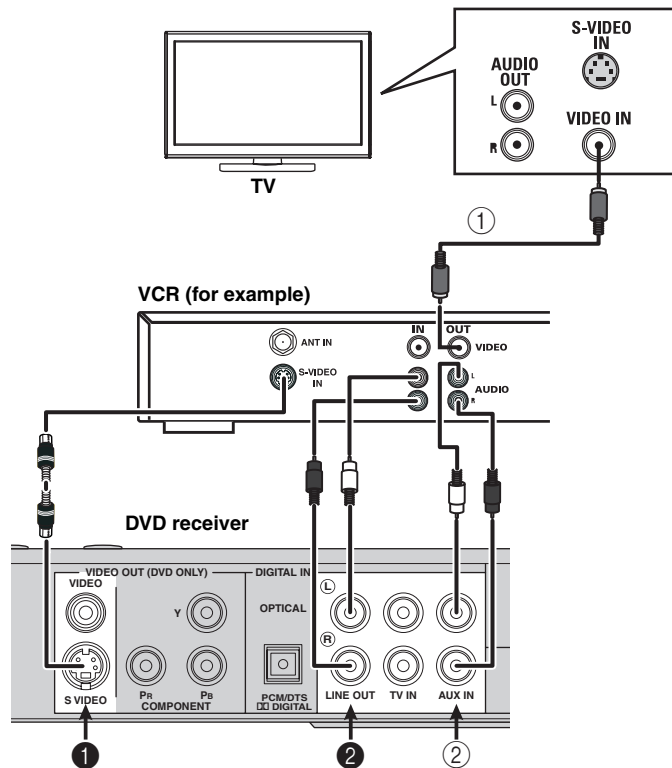

### Viewing and listening to playback

- ① Connect the VCR to the TV as shown.
- ② Connect the DVD receiver's **AUX IN** jack to the **AUDIO OUT** jacks on your VCR.  
Before starting operation, press **AUX** to select "AUX ANALOG" in order to activate the input source.

### Using the VCR for recording DVD playback

Some DVDs are copy-protected. You cannot record or dub protected discs using a VCR.

- ① Connect the DVD receiver's **S VIDEO** jack output to the **S-VIDEO IN** jack on your VCR.
- ② Connect the DVD receiver's **LINE OUT** jacks to the **AUDIO IN** jacks on your VCR.  
This will allow you to make analog stereo (two channels, right and left) recordings.

## ■ Connecting digital audio components

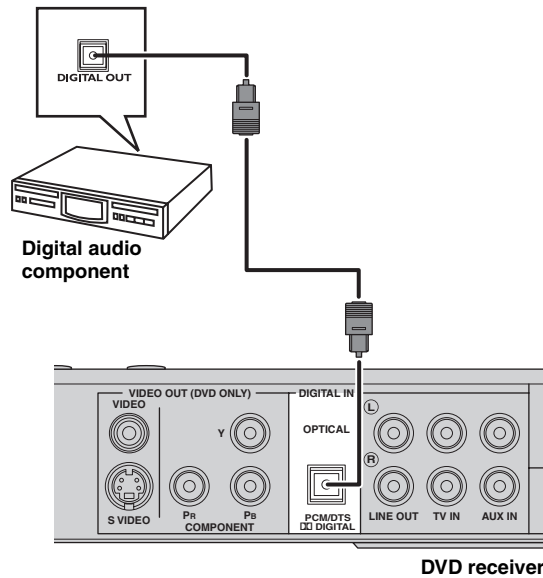

### Listening to playback

Connect the DVD receiver's **DIGITAL IN** jack to the DIGITAL OUT jack on a digital audio component. Before starting operation, press **AUX** repeatedly to select "AUX DIGITAL" in order to activate the input source.

#### Notes

- You cannot hear or record the Super Audio-CD or MP3-CD playback if you use a digital connection.
- For playback through a digital connection, set the digital output of that player to PCM format.
- Always refer to the owner's manual of the connected component for complete connection and usage details.

# GETTING STARTED

## ■ Inserting batteries into the remote control

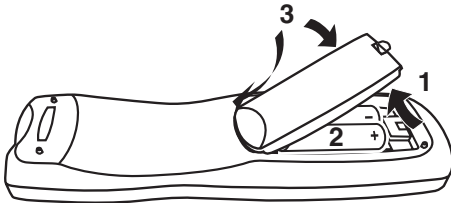

- ① Open the battery compartment.
- ② Insert two batteries type R06 or AA, following the indications (+/-) inside the compartment.
- ③ Close the battery compartment.

### To replace the batteries

If the batteries grow old, the effective operation distance of the remote control decreases considerably. If this happens, replace the batteries with two new ones as soon as possible.

#### Notes

- Do not use an old battery together with new one.
- Do not use different types of batteries (for example, alkaline and manganese) together. Each type of battery has its own characteristics even if they are similar in shape.
- If the batteries run out, immediately remove them from the remote control to prevent an explosion or acid leak.
- Dispose of the batteries according to the regional regulations.
- If a battery starts leaking, dispose of it immediately.  
Be careful not to let leaking battery acid come into contact with your skin or clothing. Before inserting new batteries, wipe the compartment clean.
- Replace the batteries within two minutes to preserve the memory in the remote control.

## ■ Using the remote control

Use the remote control within 6 m of the DVD receiver and point it toward the remote control sensor.

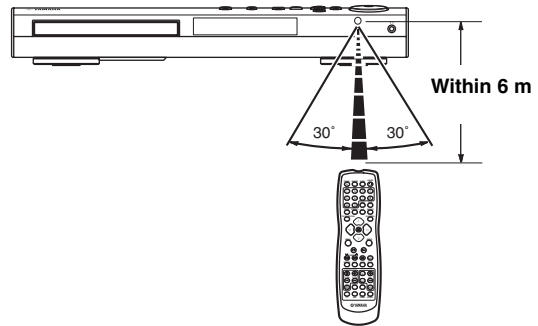

- ① Use the input selection buttons on the remote control to select the mode you wish to control (for example TV, DVD/CD).  
→ The selected source mode appears in the display panel.
- ② Select the desired function (for example,  $\triangleright$  or  $\lll / \ggg$ ).

The remote control can also operate a television, cable TV or satellite connected to the DVD receiver. However, it is first necessary to enter the remote control code for the equipment in the remote control's memory (see "LIST OF REMOTE CONTROL CODES" at the end of this manual).

#### Notes

- Be careful not to spill liquid on the remote control.
- Be careful not to drop the remote control.
- Do not leave the remote control in the following places:
  - hot or humid places, such as near a heater or in a bathroom
  - extremely cold places
  - dusty places

## ■ Setting a TV





### Note

Make sure you have completed all the necessary connections (see “Connecting a TV” on page 19).



- ① Press **DVD/CD**.  
→ “DVD/CD” appears in the display panel.
- ② Turn on the TV and set to the correct video-in channel.  
→ You should see the background screen on the TV.  
– Usually this channel is between the lowest and highest channels and may be called FRONT, A/V IN or VIDEO. See your TV manual for more details.  
– Or, you may go to channel 1 on your TV, then press the Channel down button repeatedly until you see the Video In channel.  
– Or, the TV remote control may have a button or switch that chooses different video modes.

## Selecting the TV type

In order for a DVD to play on this DVD receiver, the color system of the DVD, the TV and the DVD receiver should match. Before changing the TV system, determine the color system of your TV.

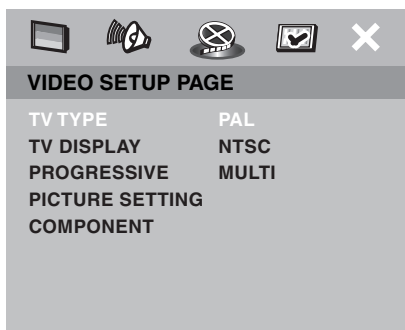
- ① In DVD/CD mode, press **SET UP**.
- ② Press  repeatedly to select [VIDEO SETUP PAGE].
- ③ Press  /  to highlight [TV TYPE], then press .



- ④ Press  /  to highlight one of the options below:
  - PAL** – Select this if the connected TV has the PAL color system. It will change the video signal of an NTSC disc and output it to PAL format.
  - NTSC** – Select this if the connected TV has the NTSC color system. It will change the video signal of a PAL disc and output it to NTSC format.
  - MULTI** – Select this if the connected TV is compatible with both NTSC and PAL (multisystem). The output format will be in accordance with the video signal of the disc.
- ⑤ Select a setting and press **ENTER (OK)**.
  - Follow the instructions shown on the TV to confirm the selection (if any).
  - If a blank/distorted TV screen appears, wait for 15 seconds for auto recovery to activate.

### Note

When you are selecting color system by using the remote control, follow the procedure below.

- ① Open the disc tray.
- ② Press , then press **AUDIO**.
  - If the default setting of the color system is **NTSC**, it will be changed to **PAL**.
  - If the default setting of the color system is **PAL**, it will be changed to **NTSC**.

## Setting the TV display

Set the aspect ratio of the DVD receiver according to the TV you have connected. The format you select must be available on the disc. If it is not, the TV display setting will not affect the picture during playback.

- ① In DVD/CD mode, press **SET UP**.
- ② Press  $\triangleright$  repeatedly to select [VIDEO SETUP PAGE].
- ③ Press  $\triangle / \nabla$  to highlight [TV DISPLAY], then press  $\triangleright$ .

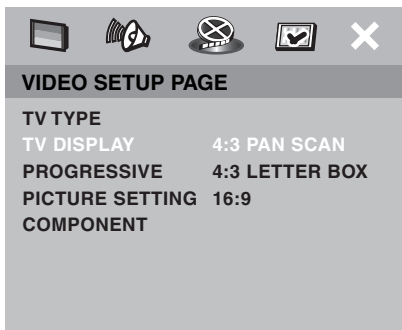

- ④ Press  $\triangle / \nabla$  to highlight one of the options below:
  - 4:3 PAN SCAN** – Select this if you have a conventional TV and want both sides of the picture to be trimmed or formatted to fit your TV screen.
  - 4:3 LETTER BOX** – Select this if you have a conventional TV. In this case, a wide picture with black bands on the upper and lower portions of the TV screen will be displayed.
  - 16:9** – Select this if you have a wide-screen TV.
- ⑤ Select a setting and press **ENTER (OK)**.

## Selecting the color system (U.K. and Europe models only)

This setting allows you to toggle the video signal output between **YUV** (Y P<sub>B</sub> P<sub>R</sub> or S-Video connections) and **RGB** (AV MONITOR OUT connections).

### Note

**AV MONITOR OUT** (SCART) connections are only available for U.K and Europe models.

- ① In DVD/CD mode, press **SET UP**.
- ② Press  $\triangleright$  repeatedly to select [VIDEO SETUP PAGE].
- ③ Press  $\triangle / \nabla$  to highlight [COMPONENT], then press  $\triangleright$ .



- ④ Press  $\triangle / \nabla$  to highlight one of the options below:
  - YUV** – Select this for Y P<sub>B</sub> P<sub>R</sub> or S-Video connections.
  - RGB** – Select this for AV MONITOR OUT connections.
- ⑤ Select a setting and press **ENTER (OK)**.
- ⑥ To return to the previous menu, press  $\triangleleft$ . To exit the menu, press **SET UP**.

## ■ Setting language preferences

You can select your preferred language settings so that this receiver will automatically switch to your preferred language whenever you load a disc. If the language selected is not available on the disc, the disc's default setting language will be used instead. The OSD (on-screen display) language for the system menu will remain as you set it, regardless of various disc languages.

### On-screen display (OSD) language

- ① In DVD/CD mode, press **SET UP**.
- ② Press  $\triangleright$  to select [GENERAL SETUP PAGE].
- ③ Press  $\triangle / \nabla$  to highlight [OSD LANGUAGE], then press  $\triangleright$ .

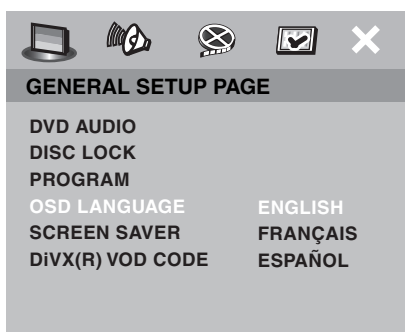

- ④ Press  $\triangle / \nabla$  to select a language and press **ENTER (OK)** to confirm.
- ⑤ To return to the previous menu, press  $\triangleleft$ .  
To exit the menu, press **SET UP**.

### Audio, Subtitle and Disc menu languages

- ① Press  $\square$  twice to stop playback (if any), then press **SET UP**.
- ② Press  $\triangleright$  repeatedly to select [PREFERENCE PAGE].
- ③ Press  $\triangle / \nabla$  to highlight one of the options below at a time, then press  $\triangleright$ .
  - [AUDIO] (disc's soundtrack)
  - [SUBTITLE] (disc's subtitles)
  - [DISC MENU] (disc's menu)







- ④ Press  $\triangle / \nabla$  to select a language and press **ENTER (OK)** to confirm.  
If the language you want is not in the list, then select [OTHERS].  
Use the **numeric keypad (0-9)** on the remote control to enter the 4-digit language code (see "LIST OF LANGUAGE CODES" at the end of this manual") and press **ENTER (OK)** to confirm.
- ⑤ Repeat steps ③ and ④ for other settings.
- ⑥ To return to the previous menu, press  $\triangleleft$ .  
To exit the menu, press **SET UP**.

## ■ Setting speaker channels



You can adjust the delay times (for center and surround speakers only) and volume level for individual speakers. These adjustments let you optimize the sound of your system to best suit your surroundings and setup.

### Note

Press **SURR** on the remote control to select the multi-channel surround mode before adjusting the speaker settings.

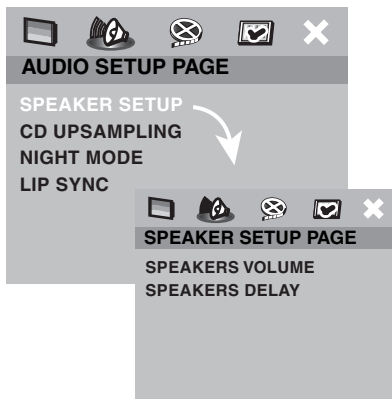
- ① Press  to stop playback, then press **SET UP**.
- ② Press  repeatedly to select [AUDIO SETUP PAGE].
- ③ Press  to highlight [SPEAKER SETUP], then press .



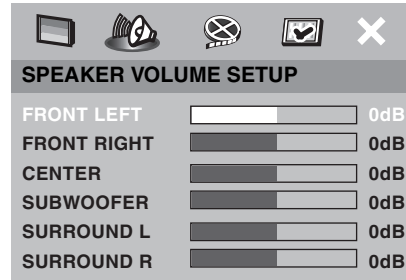

- ④ Press  to highlight one of the options below, then press .

[SPEAKER VOLUME] – Volume level setting for individual speakers (–6dB to +6dB).

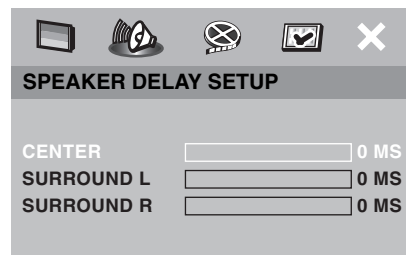

[SPEAKERS DELAY] – Delay time settings is in relation to the listening position/distance for center and surround speakers (0 MS to 15 MS).



- ⑤ Press  to adjust the setting that best suit your surround sound needs.
- ⑥ Press **ENTER (OK)** to confirm.
- ⑦ To return to the previous menu, press . To exit the menu, press **SET UP**.

### Notes

- Use a longer delay time settings when the surround speakers are closer to the listener than the front speakers.
- A test tone will be automatically generated to help you judge the sound level of each speaker.



# DISC OPERATION

## IMPORTANT!

- If the inhibit icon (⊘ or “X”) appears on the TV screen when a button is pressed, the function for that button is not available on the current disc or at the current time.
- DVD discs and players are designed with regional restrictions. Before playing a disc, make sure the disc is for the same zone as your receiver.
- Do not push on the disc tray or put any objects other than discs on the disc tray. Doing so may cause the disc player to malfunction.

## ■ Playing discs

- ① Press **DVD/CD** until “DVD/CD” appears in the display panel.
- ② Turn on the TV power and set to the correct Video In channel (see “Setting a TV” on page 24).  
→ You should see the background screen on the TV.
- ③ Press  once to open the disc tray and load a disc, then press the same button again to close the disc tray.

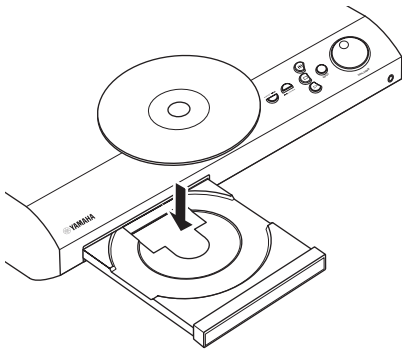

- ④ Playback will start automatically.  
→ If a disc menu shows on the TV, see “Using the disc menu” on page 30.  
→ If the disc is locked by parental control, you must enter your six-digit password (see “Restricting playback with parental control” on page 41).

## Auto eco power standby mode

This is a power-saving feature. The receiver will automatically switch to Eco Power standby mode if you do not press any buttons for 30 minutes after a disc has stopped playing.

## ■ Basic playback controls

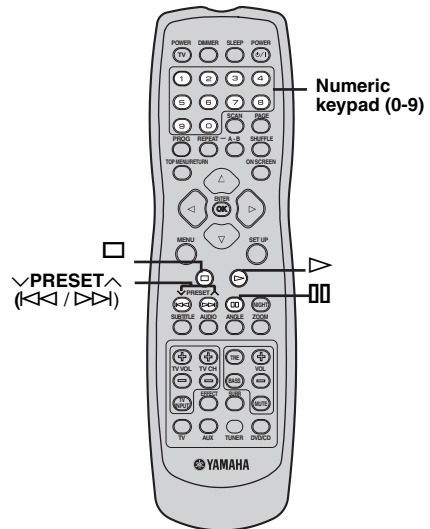





### To pause playback

During playback, press .



- To resume normal playback, press .



### To select another track/chapter

Press  /  or use the **numeric keypad (0-9)** to enter a track/chapter number.

- During repeat playback of a track/chapter, pressing  /  replays the same track/chapter.

### To search backward/forward

Press and hold  / . To resume normal chapter. Searching backward/forward playback, press .

- While searching, press  /  again to increase the search speed.

### To stop playback

Press .

## ■ Selecting various repeat shuffle functions

### Repeat play mode

#### Repeat chapter/title/disc (DVD-V)

Each time you press **REPEAT**, the display changes as follows:



↻ CHAPTER\*: repeats the current chapter.

↻ TITLE: repeats the current title.

↻ DISC\*: repeats the entire disc.

REPEAT OFF: exits repeat mode.

\* This feature may not be available with some discs.

#### Repeat track/disc (except DVD-V/DVD-A)

Each time you press **REPEAT**, the display changes as follows:



↻ TRACK: repeats the current track.

↻ DISC: repeats the entire disc.

REPEAT OFF: exits repeat mode.

#### Repeat track/group/disc (DVD-A)

Each time you press **REPEAT**, the display changes as follows:

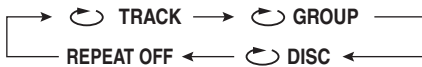

↻ TRACK: repeats the current track.

↻ GROUP: repeats the current group.

↻ DISC: repeats the entire disc.

REPEAT OFF: exits repeat mode.

#### Note

For VCD, repeat playback is not possible if the PBC mode is selected.

### Repeating a section within a chapter/track

- ① While playing a disc, press **A-B** at your chosen starting point.
- ② Press **A-B** again at your chosen end point.  
→ The section will now repeat continuously.
- ③ To exit the sequence, press **A-B**.

### ■ Shuffle (except VR format disc)

With the Shuffle function, you can play tracks in random order.

- During playback, press **SHUFFLE** repeatedly to select between SHUFFLE, SHUFFLE REPEAT and SHUFFLE OFF.  
→ The selected mode appears in the display for several seconds.
- In SHUFFLE mode, all tracks on the disc currently playing are played in random order.
- In SHUFFLE REPEAT mode, all tracks are played in random order and continuously.
- For Hybrid Super Audio CDs, tracks on the Super Audio CD layer are played by default (see “Playing Super Audio CDs” on page 34).

## Other operations for video playback (DVD/VCD/SVCD)

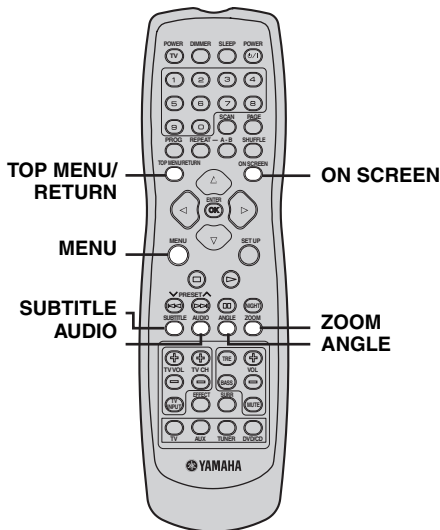

### Using the disc menu

Depending on the disc, a menu may appear on the TV screen once you load the disc.

#### To select a playback feature or item

Use  $\triangleleft$  /  $\triangleright$  /  $\triangle$  /  $\nabla$  or the **numeric keypad (0-9)** on the remote control, then press **ENTER (OK)** to start playback.

#### To access or remove the menu

Press **MENU** on the remote control.

### Displaying disc information and the current status

You can display disc information and the disc's current status (for example, title or chapter number, elapsed playing time, audio/subtitle language). A number of operations can be performed without interrupting disc playback.

- ① During playback, press **ON SCREEN**.  
→ A list of available disc information appears on the TV screen.



- ② Press  $\triangle$  /  $\nabla$  to view the information and press **ENTER (OK)** to access.
- ③ Use the **numeric keypad (0-9)** to enter the number/time or press  $\triangle$  /  $\nabla$  to make the selection, then press **ENTER (OK)** to confirm.  
→ Playback will change to the chosen time or to the selected title/chapter/track.

### Zooming in

This function allows you to enlarge the picture on the TV screen and pan through the enlarged picture.

- ① During playback, press **ZOOM** repeatedly to select a different zoom factor.  
Use  $\triangleleft$  /  $\triangleright$  /  $\triangle$  /  $\nabla$  to move through the zoomed image.  
→ Playback continues.
- ② Press **ZOOM** repeatedly to return to the original size.

### Resuming playback from the last stopped point

You can resume playback of the last 10 discs, even if the disc was ejected or this receiver's power switched off.

- ① Load one of the last played 10 discs.  
→ "LOAD" appears.
- ② Press  $\triangleright$  and the disc will be played back from the last stop point.

#### To cancel the resume mode

In stop mode, press  $\square$  again.

### Advancing by frame

- ① During playback, press **⏮** on the remote control.  
→ Play will pause and sound will be mute.
- ② Press **⏮** again to select the next picture frame.
- ③ To resume normal playback, press **▶**.

### Changing sound track language

This operation works only on DVDs with multiple soundtrack language, you can change the language you want while playing a DVD.

Press **AUDIO** repeatedly to select the available audio languages.

#### For VCD - changing the audio channel

Press **AUDIO** repeatedly to select the available audio channels provided by the disc (STEREO, LEFT MONO, RIGHT MONO or MIX MONO).

### Changing subtitle language (DVD only)

This operation works only on DVDs with multiple subtitle languages, you can change the language you want while playing a DVD.

Press **SUBTITLE** repeatedly to select from the various subtitle languages.

### Viewing from another angle (DVD only)

If the disc contains sequences recorded from different camera angles, this function allows you to view the picture from a number of different angles.

Press **ANGLE** repeatedly to select the desired angle.

→ Playback changes to the selected angle.

### Selecting a title (DVD only)

Some DVDs may contain several titles. If the disc has been recorded with a title menu recorded on it, you can start playback from the selected movie title.

- ① Press **TOP MENU/RETURN**.  
→ The disc title menu appears on the TV screen.
- ② Use **◀ / ▶ / ▲ / ▼** or the **numeric keypad (0-9)** to select a play option.
- ③ Press **ENTER (OK)** to confirm.

### Playback control (PBC) (VCD only)

PBC playback allows you to play Video CDs interactively, following the menu on the display.

This function can also be accessed via the 'PREFERENCE PAGE' menu (see "PBC" on page 42).

#### For VCDs with Playback Control (PBC) feature (version 2.0 only)

With playback stopped, press **MENU** to toggle between 'PBC ON' and 'PBC OFF'.

→ If you select 'PBC ON', the disc menu (if available) will appear on the TV. Use **◀◀ / ▶▶** or the **numeric keypad (0-9)** to select a play option and press **ENTER (OK)** to confirm.

→ If you select 'PBC OFF', the VCD will skip the index menu and playback directly from the beginning.

## Preview function

Preview function includes the following 2 types.

### Digest:

This function displays a thumbnail to help you to preview the following sections of the disc.

TITLE, CHAPTER, GROUP, TRACK

### Interval:

This function divides the following options at regular intervals to help you preview the scene you want to see.

TITLE, CHAPTER, GROUP, TRACK, DISC



(Example of 6 thumbnails in the display)

### Note

The menu appears on the TV screen differs depending on the Disc or current status (playback or stop).

## Preview title/chapter (DVD for example)

- ① Press **SCAN**.  
→ The menu appears on the TV screen.

SELECT DIGEST TYPE:  
TITLE DIGEST  
CHAPTER DIGEST  
TITLE INTERVAL  
CHAPTER INTERVAL

- ② Press  $\triangle$  /  $\nabla$  to highlight [TITLE DIGEST], [CHAPTER DIGEST], [TITLE INTERVAL] or [CHAPTER INTERVAL] and press **ENTER (OK)** to open one option.
- ③ Use  $\lll$  /  $\ggg$  to open the previous or next page.
- ④ Use  $\triangleleft$  /  $\triangleright$  /  $\triangle$  /  $\nabla$  to select a title/chapter or use the **numeric keypad (0-9)** to input the selected title/chapter number next to [SELECT].
- ⑤ Press **ENTER (OK)** to start playback from the scene you select.

### To quit the preview function

Use  $\triangleleft$  /  $\triangleright$  /  $\triangle$  /  $\nabla$  to highlight [EXIT] and press **ENTER (OK)** to confirm.

### To return to the preview menu

In step ③ and ④, use  $\triangleleft$  /  $\triangleright$  /  $\triangle$  /  $\nabla$  to highlight [MENU] and press **ENTER (OK)** to confirm.

## ■ Playing MP3/JPEG/DivX® discs

This receiver can play DivX®, MP3, JPEG, VCD and SVCD files on a personally recorded CD-R/RW disc or commercial CD.

### Note

You have to turn on your TV and set to the correct Video In channel (see “Setting a TV” on page 24).

- ① Load the disc.
  - The disc reading time may exceed 30 seconds due to the complexity of the directory/file configuration.
  - The disc menu appears on the TV screen.

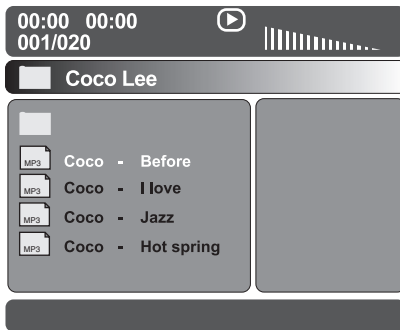

- ② Press  $\triangle$  /  $\nabla$  to select a desired folder and press **ENTER (OK)** to open the folder.
- ③ Press  $\triangle$  /  $\nabla$  to select a track/file.
- ④ Press **ENTER (OK)** to confirm.
  - Playback will start from the selected file to the end of the folder.
  - While the disc menu is displayed, you can:
    - Press  $\lll$  /  $\ggg$  to select another track/file in the current folder.
    - To select another folder from the current disc, press  $\triangleleft$  to return to the root menu, then press  $\triangle$  /  $\nabla$  to make your selection and press **ENTER (OK)** to confirm.
    - Press  $\square$  to pause or  $\triangleright$  to resume playback.

### Note

If you press  $\triangleleft$  /  $\triangleright$  /  $\triangle$  /  $\nabla$  during playback of JPEG images, the picture rotates.

## MP3 disc features

### The MP3-CD formats (ISO9660 format) support the following:

- MP3 files must have the extension “.MP3” or “.mp3”
- Max. 30 characters
- Max. nested directory is 8 levels.
- Max. album number is 99.
- Max. track number is 999.
- Supported sampling rates of 32, 44.1, 48/16, 22.05, and 24 kHz

### The following features are not supported for MP3 discs:

- The discs that have any types of file other than MP3 and JPEG.
- The simultaneous playback of the MP3 and JPEG files.
- Chinese filenames and text.
- Non-finalized closed discs.
- Discs recorded in UDF format.

### Additional note for MP3 disc playback:

- The disc read time may exceed 10 seconds due to the large number of songs compiled onto one disc.
- Multi-session discs are supported.
- The digital output signals of MP3 files are copy protected.

Downloading MP3 file from the internet or copying songs from your own legal discs is a delicate process.

## Playing MP3 music and a JPEG picture simultaneously

- ① Load an MP3 disc containing both music and picture data.  
→ The disc menu appears on the TV screen.
- ② Select an MP3 track and press ▷ to start playback.
- ③ During MP3 music playback, select a picture folder from the TV screen and press ▷.  
→ The picture files will be played back until end of the folder.
- ④ To quit simultaneous playback, press **MENU** followed by □.

### Notes

- It may not be possible to play certain MP3/JPEG/DivX® discs due to the configuration and characteristics of the disc or condition of the recording.
- It is normal to experience an occasional “skip” while listening to your MP3 disc.
- It is normal to experience an occasional pixelation during DivX® playback due to poor clarity of digital contents during internet downloading.
- For multi-session discs with different formats, only the first session will be available.

## ■ Playing Super Audio CDs

There are three types of Super Audio CD discs: single layer, double layer and hybrid discs.

Each type may contain up to two areas of recorded information: a High Quality Stereo area and a High Quality Multi-channel area.

- A single layer disc can contain both information areas.
- A dual layer disc can contain both information areas. Double the information can be stored on the disc, thanks to the second layer.
- A hybrid disc can contain both information areas, and also a second, standard CD layer, making it playable on standard CD players.

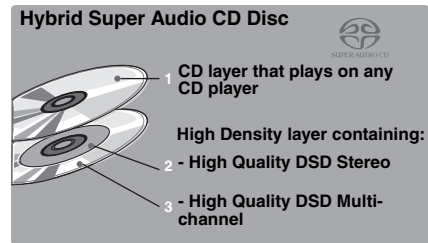
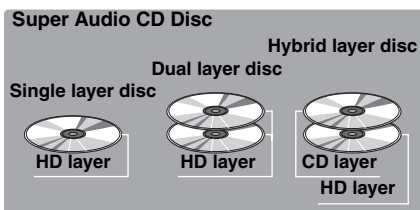

- ① Load the Super Audio CD.  
→ The disc menu appears on the TV screen.
- ② Playback will start automatically.
  - If the Super Audio CD consists of multi-channel and stereo tracks, multi-channel tracks will have the priority for playback.
  - To playback stereo tracks, use △ / ▽ to make your selection from the disc menu, then press ▷.

### Note

Programming Super Audio CD tracks is not possible.

## ■ Special features for picture disc playback

- ① Load a picture disc (Kodak Picture CD/JPEG).  
→ For Kodak discs, the slide show begins.  
→ For JPEG discs, the picture menu appears on the TV screen.
- ② Press **▷** to start the slideshow.

### Note

You have to turn on your TV and set to the correct Video In channel (see “Setting a TV” on page 24).

## Preview function

This function shows the content of the current folder or the entire disc.

- ① During playback, press **□**.  
→ 12 thumbnail pictures will appear on the TV screen.



- ② Press **◀◀ / ▶▶** to display the other pictures on the previous/next page.
- ③ Use **◀ / ▶ / △ / ▽** to highlight one of the picture and press **ENTER (OK)** to start playback.
- ④ Press **MENU** to return to the picture CD menu.

## Zooming pictures

- ① During playback, press **ZOOM** repeatedly to select a different zoom factor.
- ② Use **◀ / ▶ / △ / ▽** to move through the zoomed image.

## Multi-angle playback

During playback, use **◀ / ▶ / △ / ▽** to rotate/flip the picture on the TV screen.

- △ : flips the picture vertically.
- ▽ : flips the picture horizontally.
- ◀ : rotates the picture anti-clockwise.
- ▶ : rotates the picture clockwise.

## Scan effect

Press **ANGLE** repeatedly to choose a different scan effect.  
→ Various scan effects appear in the top left corner of the TV screen.



# DVD SETUP MENU OPTIONS

**This setup is carried out via the TV, enabling you to customize the DVD receiver to suit your particular requirements.**

## ■ General setup menu

- ① In DVD/CD mode, press **SET UP**.
- ② Press  $\triangleleft / \triangleright$  to select the [GENERAL SETUP PAGE].
- ③ Press **ENTER (OK)** to confirm.

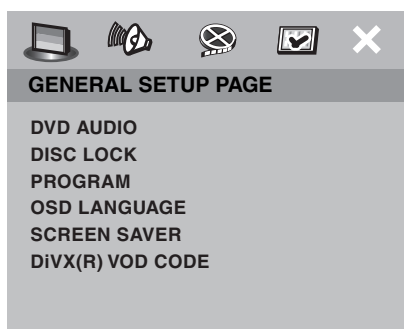

## Selecting DVD-Audio/Video mode

- ① In [GENERAL SETUP PAGE], press  $\triangle / \nabla$  to highlight [DVD-AUDIO], then press  $\triangleright$ .

### DVD-AUDIO MODE

Select this to playback the contents of the DVD-Audio.

### DVD-VIDEO MODE

Select this to playback the contents of the DVD-Video.

- ② Press  $\triangle / \nabla$  to select a setting, then press **ENTER (OK)** to confirm your selection.

### Notes

- The DVD-AUDIO indicator lights up when a DVD-Audio disc is playing.
- When you select DVD-VIDEO MODE, the DVD-AUDIO indicator goes out.

## Locking/Unlocking discs for viewing

Not all discs are rated or coded by the manufacturer of the disc. You can prevent playback of a specific disc by locking the disc. You can lock up to 40 discs on this unit.

- ① In [GENERAL SETUP PAGE], press  $\triangle / \nabla$  to highlight [DISC LOCK], then press  $\triangleright$ .

### UNLOCK

Select this to unlock the disc and allow future playback.

### LOCK

Select this to block playback of the current disc. Subsequent access to a locked disc requires a sixdigit password. The default password is '000 000' (see "Changing the password" on page 43).

- ② Press  $\triangle / \nabla$  to select a setting and press **ENTER (OK)** to confirm.

## Programming disc tracks (except picture CD/MP3/WMA/Super Audio CD discs)

You can playback the contents of a disc in the order you want by programming the tracks to be played. You can store up to 20 tracks.

### Program: Track (except for Picture CD/MP3/ WMA/DivX®)

- ① Press **PROG** on the remote control.

OR

In [GENERAL SETUP PAGE], press  $\triangle / \nabla$  to highlight [PROGRAM], then press  $\triangleright$  to select [INPUT MENU].

- ② Press **ENTER (OK)** to confirm.

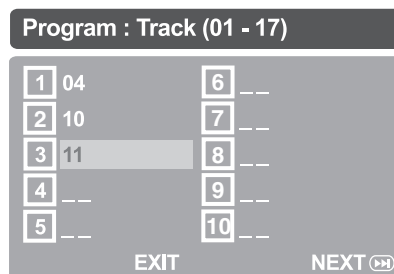

## To program your favorite tracks/chapters

- ③ Use the **numeric keypad (0-9)** to enter a valid track/chapter number.
- ④ Use  $\triangleleft / \triangleright / \triangle / \nabla$  to move the cursor to the next position.
  - If the track number is more than ten, press  $\triangleright\triangleright$  to open the next page and proceed with programming,
  - OR
  - Use  $\triangleleft / \triangleright / \triangle / \nabla$  to highlight [NEXT] on the program menu, then press **ENTER (OK)**.
- ⑤ Repeat steps ③ and ④ to input another track/chapter number.

## To remove a track

- ⑥ Use  $\triangleleft / \triangleright / \triangle / \nabla$  to move the cursor to the track you want to remove.
- ⑦ Press **ENTER (OK)** to remove this track from the program menu.
- ⑧ To exit the menu, press **PROG**.

## OSD language

This menu contains various language options for displaying languages on the screen. For details, see “On-screen display (OSD) language” on page 26.

## Screen saver

The screen saver helps prevent your TV display from becoming damaged.

- ① In [GENERAL SETUP PAGE], press  $\triangle / \nabla$  to highlight [SCREEN SAVER], then press  $\triangleright$ .

### ON

Select this if you wish to turn off the TV screen when play is stopped or paused for more than 15 minutes.

### OFF

Select this to disable the screen saver function.

- ② Press  $\triangle / \nabla$  to select a setting and press **ENTER (OK)** to confirm.
- ③ To return to the previous menu, press  $\triangleleft$ .  
To exit the menu, press **SET UP**.

## DivX®VOD registration code

Yamaha provides you with the DivX®VOD (Video On Demand) registration code that allows you to rent and purchase videos using the DivX®VOD service. For more information, go to [www.divx.com/vod](http://www.divx.com/vod).

- ① In [GENERAL SETUP PAGE], press  $\triangle / \nabla$  to highlight [DIVX(R) VOD CODE], then press  $\triangleright$ .  
→ The registration code appears.
- ② Press **ENTER (OK)** to exit.
- ③ Use the registration code to purchase or rent the videos from DivX®VOD service at [www.divx.com/vod](http://www.divx.com/vod). Follow the instructions and download the video onto a CD-R/RW for playback on this receiver.

### Notes

- All the videos downloaded from DivX®VOD can only be played back on this receiver.
- The time search function is not available during DivX® movie playback.

## ■ Audio setup menu

- ① In DVD/CD mode, press **SET UP**.
- ② Press  $\triangleleft / \triangleright$  to select [AUDIO SETUP PAGE].
- ③ Press **ENTER (OK)** to confirm.

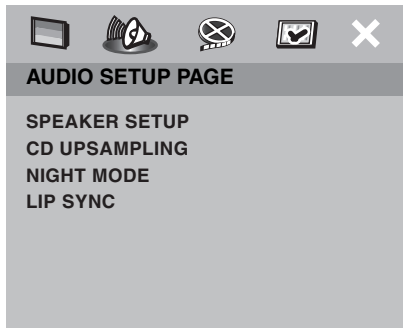

### Speaker setup

This menu contains setup options for audio output so that you can set your speakers to reproduce high quality surround sound. For details, see “Setting speaker channels” on page 27.

### CD upsampling

This feature allows you to convert your music CD to a higher sampling rate using sophisticated digital signal processing for better sound quality.

#### Note

If you have activated the upsampling function, the receiver will automatically switch to stereo mode.

- ① In [AUDIO SETUP PAGE], press  $\triangle / \nabla$  to highlight [CD UPSAMPLING], then press  $\triangleright$ .

#### OFF

Select this to disable CD-upsampling.

#### 88.2 kHz (X2)

Select this to convert the sampling rate of CDs to twice that of the original.

- ② Press  $\triangle / \nabla$  to select a setting and press **ENTER (OK)** to confirm.

#### Note

If you select “Multi-Channel” mode, the CD upsampling feature will be cancelled.

### Night mode

When night mode is activated, high volume output is softened and low volume output raised to an audible level (for DVD playback only). This is useful for watching your favorite action movie without disturbing others at night.

- ① In [AUDIO SETUP PAGE], press  $\triangle / \nabla$  to highlight [NIGHT MODE], then press  $\triangleright$ .

#### ON

Playback continues at a more even volume and “NIGHT ON” appears in the display panel.

#### OFF

Playback continues with the full dynamic range of surround sound, and “NIGHT OFF” appears in the display panel.

- ② Press  $\triangle / \nabla$  to select a setting and press **ENTER (OK)** to confirm.

#### Note

This function is only available for Dolby Digital.

### Lip synchronization

This feature allows you to delay the sound output from the center speaker in order to synchronize it with the video image. This may be necessary when using certain LCD monitors or projectors.

Choices: **0** to 200 ms

- ① In [AUDIO SETUP PAGE], press  $\triangle / \nabla$  to highlight [LIP SYNC], then press  $\triangleright$ .
- ② Press  $\triangleleft / \triangleright$  to adjust the delay time (between 0 ms and 200 ms) and press **ENTER (OK)** to confirm.

## ■ Video setup menu

- ① In DVD/CD mode, press **SET UP**.
- ② Press  $\triangleleft / \triangleright$  to select [VIDEO SETUP PAGE] icon.
- ③ Press **ENTER (OK)** to confirm.

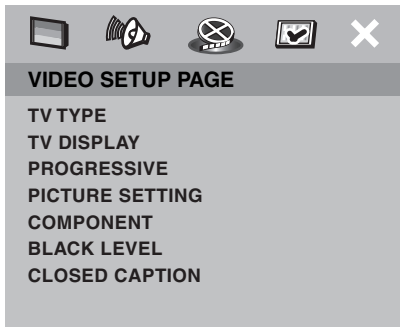

### TV type

This menu contains the options for selecting the color system that matches the connected TV. For details, see “Selecting the TV type” on page 24.

### TV display

This menu contains the options for matching the aspect ratio of the receiver to the connected TV. For details, see “Setting the TV display” on page 25.

### Progressive function

The progressive scan display present 60 complete frames per seconds, rather than 30 frames per second of interlaced scanning (ordinary normal TV system). With nearly double the number of lines, progressive scan offers higher picture resolution and eliminates bothersome motion artifacts those jagged edge on moving objects.

#### Note

Before enabling the progressive scan function, you must ensure:

- ① Turn on your TV progressive scan function (refer to your TV owner’s manual).
- ② You have connected the DVD receiver to your TV using **Y P B P R** (see “Connecting a TV” on page 19).

- ① In [VIDEO SETUP PAGE], press  $\triangle / \nabla$  to highlight [PROGRESSIVE], then press  $\triangleright$ .

#### OFF

Select this to disable progressive scan function.

#### ON

Select this to enable progressive scan function.

- ② Press  $\triangle / \nabla$  to select a setting and press **ENTER (OK)** to confirm.
  - Follow the instructions shown on the TV to confirm the selection (if any).
  - If a blank/distorted TV screen appears, wait for 15 seconds for auto recovery to activate.

#### Note

If you are changing the setting to **OFF** by using the remote control, follow the procedure below.

- ① Open the disc tray.
- ② Press  $\triangleleft$ , then press **ANGLE**.

### Picture settings

#### Note

This receiver comes with three predefined sets of picture color settings and one personal setting that you can define yourself.

- ① In [VIDEO SETUP PAGE], press  $\triangle / \nabla$  to highlight [PICTURE SETTING], then press  $\triangleright$ .

#### STANDARD

Select this for the standard picture setting.

#### BRIGHT

Select this to make the TV picture brighter.

#### SOFT

Select this to make the TV picture softer.

#### PERSONAL

Select this to personalize your picture color by adjusting the brightness, contrast, tint and color (saturation).

- ② Press  $\triangle / \nabla$  to select a setting and press **ENTER (OK)** to confirm.
- ③ If you selected [PERSONAL], proceed to step ④.
  - The [PERSONAL PICTURE SETUP] menu appears.



- ④ Press  $\triangle$  /  $\nabla$  to highlight one of the following options.

### **BRIGHTNESS**

Increase the value to brighten the picture or vice versa. Zero (0) is the average setting value.

### **CONTRAST**

Increase the value to sharpen the picture or vice versa. Zero (0) is the average contrast.

### **TINT**

Increase or decrease the value to change the color phase of the picture. Zero (0) is the average setting value.

### **COLOR**

Increase the value to enhance the color in your picture or vice versa. Zero (0) is the average color setting value.

- ⑤ Press  $\triangleleft$  /  $\triangleright$  to adjust the setting that best suits your personal preference.
- ⑥ Repeat steps ④ and ⑤ to adjust other color features if desired.
- ⑦ Press **ENTER (OK)** to confirm.

---

## **Component (U.K and Europe models only)**

This setting allows you to toggle the output of the video signal between RGB (on SCART) and Y Pb Pr (YUV).

---

## **Selecting the black level (U.S. and Canada models only)**

If you set the TV type to **NTSC**, set black level shift to **ON**. This will improve the color contrast during playback. The black level setting has no effect if the TV type is set to **PAL**. (See “Selecting the TV type” on page 24.)

### **ON**

Select this to enhance the black level.

### **OFF**

Select this for the standard black level setting.

---

## **Closed captions (U.S. and Canada models only)**

Closed captions are data hidden in the video signals of specific discs, and are invisible without the use of a special decoder. The difference between subtitles and captions is that subtitles are intended for hearing persons and captions are for the hearing impaired. Subtitles rarely show all of the audio. For example, captions show sound effects (e.g., “phone ringing” and “footsteps”), while subtitles do not. Before you select this function, please ensure that the disc contains closed caption information and your TV set also supports this function.

- ① In [VIDEO SETUP PAGE], press  $\triangle$  /  $\nabla$  to highlight [CLOSED CAPTION], then press  $\triangleright$ .

### **ON**



To enable the closed caption function.

### **OFF**

To disable the closed caption function.

- ② Press  $\triangle$  /  $\nabla$  to select a setting, then press **ENTER (OK)** to confirm your selection.

## ■ Preference setup menu

- ① Press  twice to stop playback (if necessary), then press **SET UP**.
- ② Press  /  to select the 'Preference Setup' icon.
- ③ Press **ENTER (OK)** to confirm.

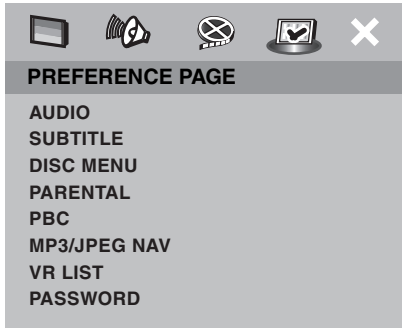



### Audio, subtitle and disc menus



These menus contain various language options for the audio, subtitle and disc menus recorded on the DVD. For details, see "Audio, Subtitle and Disc menu languages" on page 26.

## Restricting playback with parental control

Some DVDs may have a parental level assigned to the complete disc or to certain scenes on the disc. This feature lets you set a playback limitation level. The rating levels are from 1 to 8 and are country dependent. You can prohibit the playing of certain discs that are not suitable for your children, or play alternative scenes for certain discs.

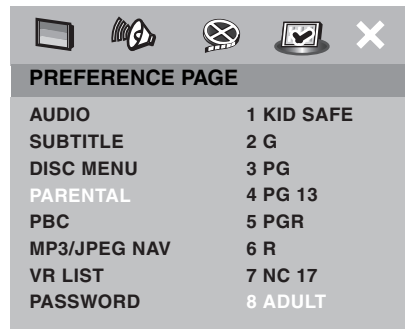
- ① In [PREFERENCE PAGE], press  /  to highlight [PARENTAL], then press .



- ② Press  /  to highlight a rating level for the disc inserted and press **ENTER (OK)**.
- ③ Use the **numeric keypad (0-9)** to enter the sixdigit password (see "Changing the password" on page 43).  
→ DVDs that are rated above the level you select will not play unless you enter the six-digit password.

---

## Rating explanation

**1 KID SAFE****2 G**

- General audience; recommended as acceptable for viewers of all ages.

**3 PG**

- Parental guidance suggested.

**4 PG13**

- Material is unsuitable for children under age 13.

**5 PGR****6 R**

- Parental guidance - restricted; recommended that parents restrict children under 17 from viewing, or allow to view only when supervised by a parent or adult guardian.

**7 NC-17**

- Material is unsuitable for children under age 17.

**8 ADULT**

- Mature material; should be viewed only by adults due to the inclusion of graphic sexual material, violence or language.

### Notes

- VCD, SVCD, CD have no level indication, so the parental control function has no effect with these types of discs. This also applies to most illegal DVDs.
- Some DVDs are not encoded with a rating though the movie rating may be printed on the disc cover. The rating level feature does not prohibit play of such discs.

---

## PBC

You can set PBC to ON or OFF. This feature is available only on Video CD 2.0 with the playback control (PBC) feature. For details, see “Playback control (PBC)” on page 31.

---

## MP3/JPEG navigator

MP3/JPEG navigator can be set only if the disc was recorded with a menu. It allows you to select different display menus for easy navigation.

- ① In [PREFERENCE PAGE], press  $\triangle$  /  $\nabla$  to highlight [MP3/JPEG NAV], then press  $\triangleright$ .

**WITH MENU**

Select this to display only the folder menu of the MP3/Picture CD.

**WITHOUT MENU**

Select this to display all the files contained in the MP3/Picture CD.

- ② Press  $\triangle$  /  $\nabla$  to select a setting, then press **ENTER (OK)** to confirm.

---

## Playback VR format discs

There are two ways to play back a VR (Video Recording) format discs: ORIGINAL LIST and PLAY LIST. This feature is not available with non-VR format discs.

- ① In [PREFERENCE PAGE], press  $\triangle$  /  $\nabla$  to highlight [VR LIST], then press  $\triangleright$ . The following settings appear:

**ORIGINAL LIST**

Select this to play the originally recorded titles on the disc.

**PLAY LIST**

Select this to play the edited version of the disc. This feature is only available when a play list has been created.

- ② Press  $\triangle$  /  $\nabla$  to highlight a setting, then press **ENTER (OK)** to confirm.

**To play back a VR format disc**

- ③ Press **SET UP** to close the setup menu.
- ④ Press **PLAY**. The setting you selected begins to play.

**To preview VR format**

- ⑤ During playback, press **SCAN**.
- ⑥ Press  $\triangle$  /  $\nabla$  to highlight either [TITLE DIGEST] or [TITLE INTERVAL].
- ⑦ Press **ENTER (OK)** to confirm.

## TITLE DIGEST

This function will display thumbnails of titles on the screen. A maximum of six thumbnails are displayed per page.

→ In ORIGINAL LIST mode, the originally recorded titles on the disc are displayed.

→ In PLAY LIST mode, every title in the play list is displayed.

## TITLE INTERVAL

This function will divide and display the contents of each title being played back in regular intervals, making it easy to preview the recording. A maximum of six thumbnails are displayed per page.

→ If the title being played back is short, the TITLE DIGEST function will be performed instead.

## Changing the password

The same password is used for both parental control and disc lock. Enter your six-digit password to play a prohibited disc or if prompted for a password. The default password is '000 000'.

- In [PREFERENCE PAGE], press  $\triangle$  /  $\nabla$  to highlight [PASSWORD], then press  $\triangleright$  to select [CHANGE].

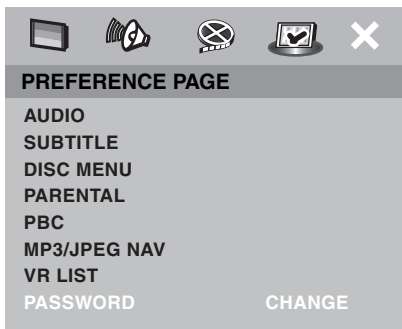

- Press **ENTER (OK)** to enter the 'Password Change Page.

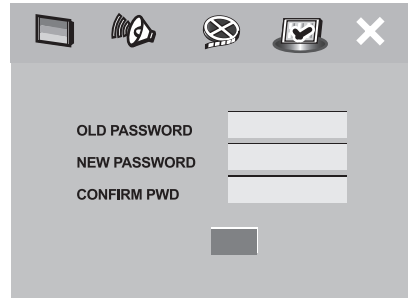

- Use the **numeric keypad (0-9)** to enter your old six-digit password.
  - When doing this for the first time, enter '000 000'.
  - If you forget your old six-digit password, enter '000 000'.
- Enter the new six-digit password.
- Enter the new six-digit password a second time to confirm.
  - The new six-digit password is now valid.
- Press **ENTER (OK)** to confirm.

## Changing the DivX subtitle

If the video downloaded from DivX®VOD has subtitles, you can select its character code.

- In [PREFERENCE PAGE], press  $\triangle$  /  $\nabla$  to highlight [DIVX SUBTITLE], then press  $\triangleright$  to select [STANDARD].
- Press **ENTER (OK)** to confirm.

### Note

If you can't read the subtitle, select [CYRILLIC].

## Restoring to the factory defaults

Setting the DEFAULT function will reset all options and your personal settings to the factory defaults, except your password for Parental Control and Disc Lock.

- In [PREFERENCE PAGE], press  $\triangle$  /  $\nabla$  to highlight [DEFAULT], then press  $\triangleright$  to select [RESET].
- Press **ENTER (OK)** to confirm.
  - All settings are reset to the factory defaults.



# TUNER OPERATIONS

## Note

Make sure the FM and AM antennas are connected to this receiver.

## ■ Tuning radio stations

- ① Press **TUNER** to select “TUNER/FM” or “TUNER/AM”.
- ② Press  $\triangle$  /  $\nabla$  briefly on the remote control.  
→ “SEARCH” appears.  
→ The next radio station is tuned automatically.
- ③ Repeat step ② (if necessary) until you find the desired radio station.
- ④ To tune weak stations, press  $\triangleleft$  /  $\triangleright$  briefly and repeatedly until the optimal reception is found.

If the FM station reception is weak, you can switch the FM mode from stereo to mono. Press **SURR** to toggle through:

- DOLBY PL II FM STEREO  
→ DOLBY PL II FM MONO
- STEREO FM MONO
- STEREO FM STEREO

## Note

(U.K. and Europe models only)

While receiving an FM station, the name of the station you selected appears in the system display panel.

## ■ Presetting radio stations

You can store up to 20 FM and 10 AM preset radio stations in this receiver’s memory.

## Notes

- The receiver will exit presetting mode if no button is pressed within 20 seconds.
- If no valid frequency is detected during Plug and Play, “CHECK ANTENNA” appears.

## Using Plug and Play

Plug and Play allows you to store all available radio stations automatically.

- ① Press **TUNER**.  
→ “AUTO PRESET” and “PRESS PLAY” appear one after the other if installation was not completed after you purchased the DVD receiver.
- ② Press  $\triangleright$  on the front panel to start installation.  
→ “AUTO PRESET” appears.  
→ Once complete, the last tuned radio station will play.  
→ All available FM stations are stored, followed by all available AM stations.

## To stop installation

Press  $\square$ .

## Automatic presetting

You can start automatic presetting by pressing a selected preset number.

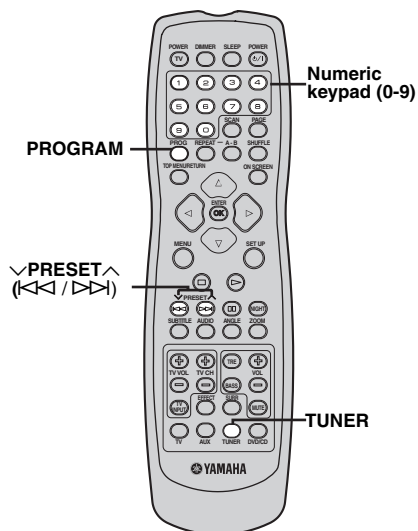

- ① Press **TUNER** to select “TUNER/FM” or “TUNER/AM”.
- ② Press  $\triangleleft\triangleleft$  /  $\triangleright\triangleright$  or use the **numeric keypad (0-9)** to select a preset number to begin.

- ③ Press and hold **PROG** until “AUTO PRESET” appears.  
 → If a radio station is stored in one of the earlier presets, the same radio station will not store under another preset number.  
 → If no preset number is selected, automatic preset will begin from preset (1) and all former presets will be overridden.

---

## Manual presetting

You can choose to store only your favourite radio stations.

- ① Tune the desired radio station (see “Tuning radio stations” on page 44).
- ② Press **PROG**.
- ③ Press **◀◀ / ▶▶** to select a preset number.
- ④ Press **PROG** again to store.

---

## Selecting a preset radio station

Press **◀◀ / ▶▶** or use the **numeric keypad (0-9)** to select a preset number.

→ The waveband, preset number, then radio frequency appears.

---

## Deleting a preset radio station

Press and hold **□** on the front panel until “AM XX DELTD” or “FM XX DELTD” (XX: preset number) appears.

→ The current preset radio station is deleted.

## Setting frequency step (Asia except Korea model)

The inter-station frequency spacing differs depending on the areas. Set the frequency step according to the frequency spacing in your area.

Choices: AM9kHz/FM50kHz, AM10kHz/FM100kHz

Default setting: AM9kHz/FM50kHz

## To change the AM band to 10kHz and the FM band to 100kHz

- ① Unplug the AC power cord from the DVD receiver and wait at least one minute.
- ② While pressing and holding **INPUT** and **◀◀** on the front panel, plug the AC power cord to the DVD receiver.
- ③ After “CINEMA STATION” scrolls in the display panel, release the keys.

### Note

Repeat the above steps ① to ③ to change AM band to 9kHz and FM band to 50kHz.

# SOUND CONTROLS

## Note

For proper surround sound, make sure the speakers and subwoofer are connected to this receiver (see “Connecting the subwoofer” on page 17).

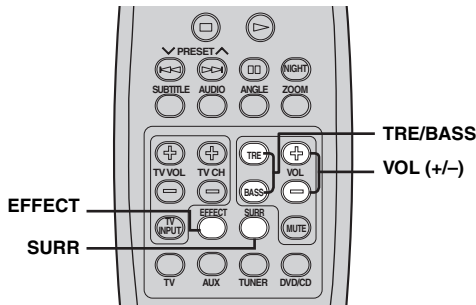

## ■ Selecting surround sound

- Press **SURR** on the remote control to select: MULTI-CHANNEL or STEREO.
  - The availability of the various surround sound modes depends on the number of speakers used and the sound available on the disc.
  - The center and surround speakers operate only in multi-channel surround mode.
  - Stereo broadcasts or recordings produce some surround channel effects when played in a surround mode. However, mono (single channel sound) sources do not produce any sound from the surround speakers.

## Note

The surround sound mode cannot be selected if the system setup menu is selected.

## ■ Selecting digital sound effects

You can select preset digital sound effects that match the content of your disc, or that optimize the sound of the musical style you are playing.

Press **EFFECT** to select from the available sound effects.

When playing movie discs or while in TV mode, you can select:

CONCERT, DRAMA, ACTION or SCI-FI.

When playing music discs or while in TUNER or AUX mode, you can select:

ROCK, DIGITAL, CLASSIC or JAZZ.

## Notes

- Digital sound effects and the treble/bass features cannot be activated at the same time.
- For flat sound output, select CONCERT or CLASSIC.

## ■ Adjusting the treble/bass level

The TREBLE (high tone) and BASS (low tone) features enable you to define the sound-processor settings.

- ① Press **TRE** or **BASS** on the remote control.
- ② Within five seconds, press **VOL (+/-)** to adjust the treble or bass level (MIN, -2, -1, 0, +1, +2 or MAX).  
→ If the volume control is not used within five seconds, it will resume its normal volume control function.

## ■ Adjusting the volume level

Use the **VOLUME** control (or press **VOL (+/-)** on the remote control) to increase or decrease the volume level.

→ “VOL MIN” is the minimum volume level and “VOL MAX” is the maximum volume level.

### To mute the volume temporarily

Press **MUTE** on the remote control.

– Playback continues without sound and “MUTE” appears.

– To restore the volume, press **MUTE** again or increase/decrease the volume level.

## ■ Night listening mode

When night listening mode is activated, high volume output is softened and low volume output raised to an audible level (for DVD playback only). This is useful for watching your favorite action movie without disturbing others at night.

This function is only available for Dolby Digital.

– Press **NIGHT** on the remote control to activate the night listening mode.

→ Playback continues at a more even volume and “NIGHT ON” appears in the display panel.

– To restore the volume, press **NIGHT** again.

→ Playback continues with the full dynamic range of surround sound, and “NIGHT OFF” appears in the display panel.

## ■ Switching to active mode

– Press **TUNER** repeatedly on the remote control to select the appropriate active mode.

Each time you press **TUNER**, the front display changes as follows:

TUNER/FM  
  
 TUNER/FM

– Press **AUX** repeatedly on the remote control to select the appropriate active mode.

Each time you press **AUX**, the front display changes as follows:

AUX/ANALOG  
  
 AUX/DIGITAL

## ■ Switching to standby mode

Press **STANDBY/ON** on the front panel or **POWER** (⏻/I) on the remote control.

→ The display screen goes blank.

# OTHER FUNCTIONS

## ■ Setting remote control codes

Once you set the appropriate remote control codes, you can use this remote to control your other components. The remote control automatically switches to the appropriate control mode for that component.

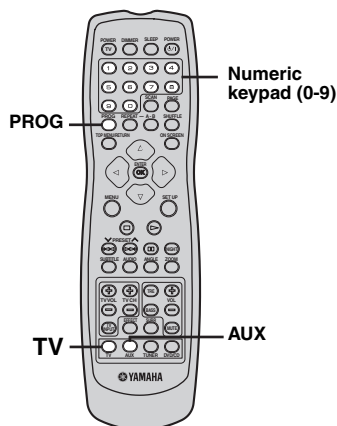

For **TV**, you can set a TV remote control code and for **AUX**, you can set a cable or satellite tuner remote control code.

- ① Press and hold **TV** or **AUX**.
- ② Press **PROG**, then release both keys.
- ③ Press the **numeric keypad (0-9)** to enter the 4 digit remote control codes (see “LIST OF REMOTE CONTROL CODES” at the end of this manual).
- ④ Press **PROG** again to store.

## ■ Controlling other components

You can operate other components if you have set the remote control code for your component in the remote control. Note that some buttons may not correctly operate the selected component.

### TV operations

Press **TV** for TV operations.

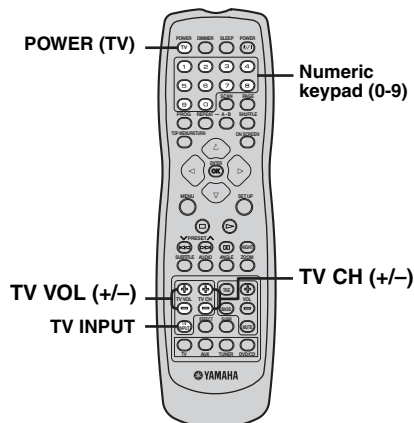

### Functions for TV operation

#### **POWER (TV)\***

Turns on the TV, or sets it to the standby mode.

#### **TV VOL (+/-)\***

Adjusts the TV volume level.

#### **TV INPUT\***

Switches the TV inputs.

#### **Numeric keypad (0-9)**

Enters a number of a TV channel.

#### **TV CH (+/-) \***

Switches TV channels.

\* You can also operate these functions in DVD/ CD or TUNER mode.

## Cable and satellite tuner operations

Press **AUX** for the cable and satellite tuner operations.

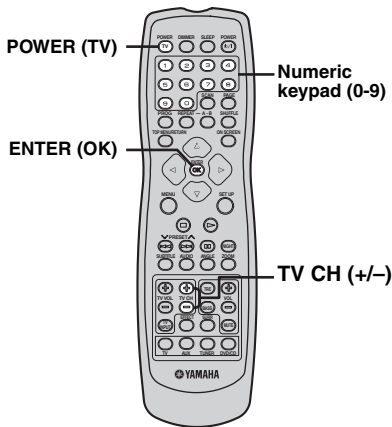

### Functions for cable and satellite tuners

#### POWER (TV)

Turns on the cable and satellite tuner, or sets them to the standby mode.

#### ENTER (OK)

Confirms a selection.

#### Numeric keypad (0-9)

Cable: enters a number of a cable channel.

Satellite tuner: enters a number of a preset radio station.

#### TV CH (+/-)

Switches the cable or satellite tuner channel.

## ■ Dimming the display screen

In any active mode, press **DIMMER** on the remote control to select the desired brightness:

DIM 1: 70% brightness

DIM 2: 40% brightness

DIM OFF: normal brightness

## ■ Setting the sleep timer

The sleep timer switches the receiver to Eco Power standby mode automatically at the preset time.

- ① Press **SLEEP** on the remote control until “SLEEP XX” appears in the display panel (XX: 15, 30, 45, 60 or OFF).
- ② To select the next sleep timer value, continue pressing **SLEEP** while in sleep timer mode until the desired turn-off time is displayed.
  - “SLEEP” appears in the display panel, except when “SLEEP OFF” is selected.
  - Before the receiver switches to Eco Power standby mode, a countdown of 10 seconds is displayed.
  - “SLEEP 10” → “SLEEP 9”... →
  - “SLEEP 2” → “SLEEP 1”

### To cancel the sleep timer

Press **SLEEP** until “SLEEP OFF” appears.

## ■ Recording on an external AV component

- ① Connect the external recording component to **LINE OUT** (see “Connecting external AV components” on page 21).
- ② Select the source to record from this DVD receiver (**DVD/CD, TUNER, TV** or **AUX**) and start playback (if necessary).
- ③ Start recording on the external recording device.

#### Note

Refer to the owner’s manual of the connected component for details.

# TROUBLESHOOTING

If there is any problem with your CinemaStation system, check the following items. If you cannot solve your problem with the following remedies or if your problem is not listed below, turn off and unplug the CinemaStation, then consult the nearest authorized YAMAHA dealer or service center.

Problem	Solution
<b>No power</b>	Check if the AC power cord is properly connected.
	Press STANDBY/ON on the front of the receiver to turn on the power.
<b>No picture</b>	Refer to your TV's manual for correct Video In channel selection. Change the TV channel until you see the DVD screen.
	Press DVD/CD on the remote control in order to switch to DVD/CD mode.
<b>Completely distorted picture or black/white picture</b>	If this happens when you are changing the setting of the 'TV TYPE', wait for 15 seconds for auto recovery.
	If this happens when you are turning on the progressive scan feature, wait for 15 seconds for auto recovery.
	Check the video connection.
	Sometimes a small amount of picture distortion may appear. This is not a malfunction.
<b>The aspect ratio of the screen cannot be changed even though you have set the TV display</b>	Clean a disc.
	The aspect ratio is fixed on the DVD disc.
<b>No sound or distorted sound</b>	Depending on the TV, it may not be possible to change the aspect ratio.
	Adjust the volume.
	Check if the system cable is properly connected.
	Check if all speaker cables are properly connected.
	Make sure that the audio cables are connected and press the Input selection buttons to select the correct input source (TV or AUX, for example) to choose the equipment that you want to hear through the DVD receiver.
	Check if the AC power cord of the subwoofer is properly connected.
<b>No sound or picture</b>	Make sure that you use a disc supported by the DVD Player.
	Check that the RGB/SCART cable is connected to the correct device (see "Connecting a TV" on page 19).
<b>Sound is too low on one side</b>	Check if all cables are properly connected.
<b>Cannot activate some features such as Angles, Subtitles, or multi-language Audio</b>	The features may not be available on the DVD.
	Changing the language for the sound or subtitle is prohibited on the DVD.
<b>DVD videos cannot be copied with the VCR</b>	Most commercially available DVD's include copy protect features. You cannot make a copy of these DVD's.
<b>The disc is ejected without an operation</b>	Make sure that you use a disc supported by the DVD receiver.
<b>Not able to select some items in the setup/system menu</b>	Press STOP twice before selecting the setup/system menu.
	Depending on the disc availability, some menu items cannot be selected.
<b>The DVD receiver does not start playback</b>	Insert a readable disc with the playback side facing down. The DVD-R/DVD+R/DVD-RW/DVD+RW/CD-R/CD-RW/DVD-RW (VR format) must be finalized.
	Check the disc type, color system (PAL or NTSC) and region code.
	Check for any scratches or smudges on the disc.
	Press SET UP to turn off the setup menu screen.
	You may need to enter the password in order to change the parental control rating level or to unlock the disc for playback.
	Moisture has condensed inside the player. Remove the disc and leave the receiver turned on for about an hour.

Problem	Solution
Sound played on the DVD receiver cannot be recorded with an external recorder	Use proper audio sources.
Sounds played on the AV equipment connected to the DVD receiver cannot be recorded with external recording equipment	Connect those equipment to the DVD receiver with along connections.
The volume does not increase or sounds are distorted	Turn on the power of the component connected to the DVD receiver.
There is no sound from the center, surround speakers and subwoofer	Make sure the center, surround speakers and subwoofer are connected correctly.
	Adjust the volume level in the setup menu.
	Press SURR button to select a correct surround sound setting.
	Make sure the source you are playing is recorded or broadcast in surround sound (DTS, Dolby Digital, etc.).
"SPEAKER ERR" appears in the display panel	Unplug the subwoofer, then make sure the front, center and surround speakers are connected correctly.
	Set the DVD receiver to the standby mode, then disconnected the power cord. Wait for about 30 seconds, then reconnect the power cord and turn on the DVD receiver.
Radio reception is poor	If the signal is too weak, adjust the antenna or connect an external antenna for better reception.
	Increase the distance between the receiver and your TV or VCR.
	Tune in to the correct frequency.
	Place the antenna farther away from any equipment that may be causing the noise.
The remote control does not function properly	Select the source (DVD/CD or TUNER, for example) before pressing the function button (▷, ◀◀ / ▷▷).
	Reduce the distance between the remote control and the receiver.
	Replace the batteries with new ones.
	Point the remote control directly toward the remote control sensor.
	Check that the batteries are loaded correctly.
The remote control does not work for operating other equipment	Set the correct remote control code. Depending on the model and year of the product, the DVD receiver's remote control may not be able to operate it partly or wholly. In this case, use the remote control supplied with each product.
Unable to play DivX® movies	Check that the DivX® file was encoded in 'Home Theater' mode with a DivX® 5.x encoder.
The DVD receiver does not work	Disconnect the power cord from the power outlet for a few minutes. Reconnect the power cord and try to operate again as usual.



# GLOSSARY

## **Analog**

Sound that has not been turned into numbers.

Analog sound varies, while digital sound has specific numerical values. These jacks send audio through two channels, the left and right.

## **Aspect ratio**

The ratio of vertical and horizontal sizes of a displayed image. The horizontal vs. vertical ratio of conventional TVs. is 4:3, and that of wide-screens is 16:9.

## **Bit**

Short for binary digit. Represents the smallest unit of information manipulated on a computer. In audio systems, the bit size determines resolution to digitize analog signals.

The larger the bit size, the larger the dynamic range (the ratio of maximum and minimum frequency level) and the finer the sounds. Generally, an audio CD is 16 bit and DVD audio is 24 bit.

## **Bit rate**

The amount of data used to hold a given length of music; measured in kilobits per second, or kbps. Also, the speed at which you record. Generally, the higher the bit rate, or recording speed, the better the sound quality. However, higher bit rates use more space on a disc.

## **COMPONENT VIDEO OUT**

Jacks for inputting or outputting a component video signal. Component video signal consists of three lines, the luminance signal (Y) and two color difference signals ( $P_B/C_B$ ,  $P_R/C_R$ ), which enable to provide high-quality video.

## **Disc menu**

A screen display prepared for allowing selection of images, sounds, subtitles, multi-angles, etc. recorded on a DVD.

## **DivX**

DivX® is a video compression technology developed by DivX® Networks, Inc. It compresses digital video data to sizes small enough to be transported over the Internet without reducing the original video quality. You need DivX codec software to play back DivX movies or convert data to the DivX format.

## **Dolby Digital**

Digital surround sound system which is developed by Dolby Laboratories provides completely independent multi-channel audio. With 3 front channels (left, center, and right) and 2 surround stereo channels, Dolby Digital provides five full-range audio channels. With an additional channel especially for bass effects (called LFE, or low frequency effect), the system has a total of 5.1-channels (LFE is counted as 0.1 channel). By using 2-channel stereo for the surround speakers, more accurate moving sound effects and surround sound environment are possible than with Dolby Surround.

## **Dolby Surround Pro Logic II**

It is an improved matrix decoding technology that provides better spatiality and directionality on Dolby Surround programme material; provides a convincing three-dimensional soundfield on conventional stereo music recordings; and is ideally suited to bring the surround experience to automotive sound. While conventional surround programming is fully compatible with Dolby Surround Pro Logic II decoders, soundtracks will be able to be encoded specifically to take full advantage of Pro Logic II playback, including separate left and right surround channels. (Such material is also compatible with conventional Pro Logic decoders).

## **DTS (Digital Theater Systems)**

Digital surround sound system developed by Digital Theater Systems, Inc., which provides 5.1 channel audio (max). With an abundance of audio data, it is able to provide authentic-sounding effects.

## **Interlace**

The most common type of scanning used in televisions. It divides a screen into even and odd numbered fields for scanning, and then builds an image by combining them into one image (frame).

## **JPEG (Joint Photographic Expert Group)**

A standardized image compression system proposed by the Joint Photographic Expert Group. It can reduce image data sizes to 1 to 10% of their original sizes, and works on digital photographs effectively.

## **MP3 (MPEG Audio Layer-3)**

An audio file compression technology. It can reduce audio data sizes to about 10% of their original sizes while maintaining CD-level audio quality.

## **MPEG (Moving Pictures Experts Group)**

International standard for digital video and audio compression generated by ISO (International Organization for Standardization) and IEC (International Electrotechnical Commission). Includes MPEG-1, MPEG-2, and MPEG-3. MPEG-1 offers VHS level video quality and is often used on video CDs. MPEG-2 offers S-VHS level video quality and is often used on DVDs.

**Parental control**

Limits Disc play according to the age of the users or the limitation level in each country. The limitation varies from disc to disc; when it is activated, playback will be prohibited if the software's level is higher than the user-set level.

**Playback control (PBC)**

An on-screen menu recorded on a Video CD or SVCD that enables interactive playback and searching.

**Progressive Scan**

A method of displaying all scanning lines in a frame at once, reducing flicker noticeable on a larger screen and creating a sharp and smooth image.

**Region code**

Many DVD discs include a region code so that the copyright owner can control DVD software distribution only to regions where they are ready to distribute. There are six regions codes, which restrict a DVD player to playing a DVD disc with the same region code.

**S-video output**

A jack for inputting or outputting an S-video signal. S-video signal consists of two lines, the luminance signal (Y) and color signal (C), which enable to provide high-quality video during playback or recording.

**Super Audio CD**

This audio format is based upon the current CD standards but includes a greater amount of information that provides higher quality sound. There are three types of discs: single layer, double layer and hybrid discs. The hybrid disc can be played on existing CD players as well as Super Audio players since it contains both standard audio CD and Super Audio CD information.

**Surround**

A receiver for creating realistic three-dimensional sound fields full of realism by arranging multiple speakers around the listener.

**VR format (Video Recording format)**

A DVD video recording format, which allows editing DVD video data recorded onto a disc. You need a VR format compatible player for playback.

# SPECIFICATIONS

## DVD RECEIVER DVX-S300

### TUNER SECTION

FM Tuning Range	87.50 to 108.00 MHz
AM Tuning Range	
- Canada model	530 to 1700 kHz
- Europe, U.K., Australia and Korea models	531 to 1602 kHz
- Taiwan and Asia models	531 to 1602 kHz/530 to 1700 kHz

### DISC SECTION

Laser Type	Semiconductor
Disc Diameter	12 cm/8cm
Video Decoding	MPEG-1 /MPEG-2/DivX 3.11, 4.x & 5.x
Video DAC	12 bits/108 MHz
Signal System	PAL/NTSC
Video Format	4:3/16:9
Composite Video Output	1.0 Vp-p, 75 ohm
S-video Output	Y - 1.0 Vp-p, 75 ohm C - 0.3 Vp-p, 75 ohm
RGB (SCART) output	0.7 Vp-p, 75 ohm
Component Video Output	Y - 1.0 Vp-p, 75 ohm PB/CB PR/CR - 0.7 Vp-p, 75 ohm
Audio DAC	24 bits/192 kHz
Frequency Response	4 Hz - 20 kHz (44.1 kHz) 4 Hz - 22 kHz (48 kHz) 4 Hz - 44 kHz (96 kHz)
Audio S/N	105 dB
Distortion	0.0035%
Dynamic Range	95 dB

### AUDIO FORMAT

Digital	Dolby Digital/DTS/MPEG Compressed Digital
	PCM
	16, 20, 24 bits
	fs 44.1, 48, 88.2, 96, 176.4, 192 kHz
	MP3 (ISO 9660)
	24, 32, 56, 64, 96, 128, 256 kbps
	fs 16, 22.05, 24, 32, 44.1, 48 kHz
	WMA
	32 to 192 kbps, mono, stereo
	Full decoding of Dolby Digital and DTS multi-channel sound
	Dolby Surround Compatible Downmix from Dolby Digital multi-channel sound
	Dolby Pro Logic II

### GENERAL

Power Supply	
- Canada model	120 V, 60 Hz
- Australia model	240 V, 50 Hz
- Europe and U.K. models	
	230 V, 50 Hz
- Taiwan model	110-120 V, 50/60 Hz
- Asia model	220-240 V, 50/60 Hz
- Korea model	220 V, 60 Hz
Power Consumption	15W
Frequency Response	20 Hz to 20 kHz/-3 dB (Front, Center, Surround)
Signal-to-Noise Ratio	> 95 dB
Input Sensitivity	
- AUX In, TV In	300 mV
- SCART In	
	(Europe and U.K. models only)
	500 mV
Dimensions (W x H x D)	360 x 53 x 310 mm
Weight	2.7 kg

## CENTER SPEAKER

### NX-C301

System	2-way system
Impedance	6 Ω
Speaker Drivers	7.0 cm woofer x 2 + 1.9 cm tweeter
Frequency Response	100 Hz - 20 kHz
Dimensions (W x H x D)	300 x 84 x 78 mm
Weight	1.0 kg

### NX-C302

System	Full range system
Impedance	6 Ω
Speaker Drivers	5.0 cm Full range x 3
Frequency Response	100 Hz - 20 kHz
Dimensions (W x H x D)	328 x 98 x 64 mm (with stand)
Weight	0.7 kg

## FRONT AND SURROUND SPEAKERS

### NX-S301

System	2-way system
Impedance	6 Ω
Speaker Drivers	7.0 cm woofer + 1.9 cm tweeter
Frequency Response	100 Hz - 20 kHz
Dimensions (W x H x D)	83 x 181 x 78 mm
Weight	0.6 kg

### NX-S302

System	Full range system
Impedance	6 Ω
Speaker Drivers	5.0 cm Full range + 2.5 cm piezo tweeter
Frequency Response	100 Hz - 20 kHz
Dimensions (W x H x D)	210 x 994 x 210 mm (with stand)
Weight	3.0 kg

**SUBWOOFER****NX-SW300**

Power Supply Rating	110–120 V, 50/60 Hz
- Taiwan model	110–120 V, 50/60 Hz
- Asia model	220–240 V, 50/60 Hz
- Korea model	220 V, 60 Hz
Power Consumption	360 W
System	Bass Reflex System
Impedance	6 $\Omega$
Speaker Driver	16 cm woofer
Frequency Response	40 Hz – 100 Hz
Dimensions (W x H x D)	178 x 402 x 461 mm
Weight	12 kg

**Amplifire Section**

Output Power	
- Front	150 W (10% THD, 1 kHz)/channel
- Surround	150 W (10% THD, 1 kHz)/channel
- Center	150 W (10% THD, 1 kHz)
- Subwoofer	150 W (10% THD, 100 Hz)

**NX-SW301**

Power Supply Rating	
- Canada model	120 V, 60 Hz
- Australia Model	240 V, 50 Hz
- Europe and U.K. models	230 V, 50 Hz
- Taiwan model	110–120 V, 50/60 Hz
- Asia model	220–240 V, 50/60 Hz
- Korea model	220 V, 60 Hz
Power Consumption	200 W
System	Bass Reflex System
Impedance	6 $\Omega$
Speaker Driver	16 cm woofer
Frequency Response	40 Hz – 100 Hz
Dimensions (W x H x D)	200 x 390 x 382 mm
Weight	11.5 kg

**Amplifire Section**

Output Power	
- Front	75 W (10% THD, 1 kHz)/channel
- Surround	75 W (10% THD, 1 kHz)/channel
- Center	75 W (10% THD, 1 kHz)
- Subwoofer	75 W (10% THD, 100 Hz)

Specifications subject to change without prior notice.



# LIST OF REMOTE CONTROL CODES LISTE DES CODES DE COMMANDE

## TV

Yamaha	1009, 1011, 1036, 1068
Admiral	1033, 1080
Aiko	1032
Akai	1011
Alba	1005, 1013, 1014, 1064, 1076
AOC	1009, 1011
Audiovox	1032, 1053, 1079, 1083
Belcor	1009
Bell & Howell	1007, 1039
Blaupunkt	1055, 1056, 1059, 1082
Blue sky	1064
Bradford	1053
Brandt	1035, 1057, 1058
Brokwood	1009
Bush	1005, 1013, 1014, 1064, 1070, 1072, 1076, 1077
Candle	1011, 1021
Clatronic	1030, 1067, 1075
Contec	1053
Craig	1043, 1053
Croslex	1020
Crown	1016, 1053, 1078
Curtis Mathis	1007, 1011, 1016, 1017, 1018, 1020, 1021, 1022
CXC	1053
Daewoo	1009, 1016, 1023, 1032, 1039, 1079, 1083, 1084
Daytron	1009
Dual	1063
Dumont	1008, 1009
Emerson	1009, 1015, 1016, 1039, 1050, 1051, 1052, 1053, 1065, 1070, 1080, 1083, 1084
Envision	1011
Ferguson	1004, 1014, 1028, 1035, 1054, 1066, 1071
First line	1005, 1062, 1063, 1067, 1072, 1074
Fisher	1039
Funai	1048, 1052, 1053, 1069
Futuretec	1053
GE	1010, 1017, 1018, 1033, 1051, 1070, 1079, 1088, 1090
Gibraltar	1008, 1009, 1011
LG/Goldstar	1002, 1003, 1009, 1011, 1014, 1016, 1021, 1052
Goodmans	1013, 1014, 1027, 1063, 1076, 1077
Grundig	1026, 1055, 1056, 1082
Harvard	1024, 1053
Hitachi	1015, 1021, 1036
ICE	1063, 1069, 1076
Itt/Nokia	1044
JC Penny	1003, 1009, 1010, 1011, 1016, 1017, 1018, 1021, 1022, 1040, 1051, 1090
JVC (Victor)	1013, 1019, 1025, 1042
Kendo	1014
Kenwood	1009, 1011
KTV	1011, 1016, 1053
Loewe	1029
Magnavox	1011, 1013, 1020, 1052
Marantz	1011, 1014, 1020
Matsui	1005, 1012, 1013, 1014, 1027, 1060, 1063, 1072, 1076
MGA	1009, 1011, 1037, 1049
Mitsubishi	1009, 1033, 1034, 1038, 1081
MTC	1009, 1011, 1021, 1022, 1062, 1081
Multitec	1053
NEC	1009, 1011, 1013, 1021, 1047
Nikko	1011, 1032, 1051
Nokia	1044
Nordmende	1035, 1057, 1058, 1071
NTC	1062
Oceanic	1044, 1061
Onwa	1053
Panasonic	1018, 1043, 1068, 1086
Philco	1009, 1011, 1020, 1036, 1080
Philips	1014, 1020

Pilot	1009, 1011, 1016
Pioneer	1015, 1046, 1049, 1085, 1086
Portland	1009, 1016, 1032
Quasar	1018, 1045, 1068
Radio Shack	1009, 1011, 1016, 1017, 1021, 1038, 1044, 1049, 1051
RCA	1009, 1015, 1017, 1018, 1031, 1033, 1087, 1088, 1089, 1090, 1091
Realistic	1009, 1011, 1016, 1021, 1039, 1045, 1051, 1053
SABA	1029, 1035, 1044, 1057, 1058, 1071
Sampo	1011, 1016
Samsung	1009, 1011, 1014, 1021, 1022, 1031, 1051
Sanyo	1039, 1060, 1079
Schneider	1014, 1064, 1067, 1073, 1076
Scott	1009, 1051, 1052, 1053, 1065
Sharp	1016, 1033, 1045
Shogun	1009
Siemens	1014, 1041, 1055, 1056, 1059, 1082
Signature	1007
Sony	1001, 1006
Soundesign	1051, 1052, 1053
Starlite	1053
Sylvania	1011, 1020
Telefunken	1021
Thomson	1035, 1057, 1058, 1071
Toshiba	1012, 1013, 1022, 1039, 1040
Videch	1009, 1013, 1051
Wards	1007, 1009, 1010, 1011, 1020, 1021, 1045, 1051, 1052

## CABLE

ABC	3002, 3003, 3004, 3006, 3008
Andover	3037
Bell & Howell	3006
Birmingham Cable	3020
Communication	
British Telecom	3002, 3012
Cabletime	3016, 3019, 3025, 3029
Contec	3009
Clyde	3011
Cryptovision	3038
Daehan	3043
Daeryung	3003
Decsat	3027
Everquesst	3007
Filmnet	3028
France Telecom	3030
GEC	3011
Gemini	3007
General Instrument	3004, 3020, 3031, 3046
Goldstar	3014, 3047
Grundig	3035
Hamlin	3052, 3067, 3050, 3057, 3068
Hitachi	3004
Jasco	3007
Jerrold	3002, 3004, 3005, 3006, 3007, 3020, 3031, 3046
LG Alps	3044
Magnavox	3055, 3071
Memorex	3001
Mnet	3009, 3028
Motorola	3074, 3075, 3076 3077, 3078, 3079, 3080, 3081, 3082, 3083, 3084, 3085, 3086, 3087, 3088, 3089, 3090, 3091
Now	3041
Oak	3009
Pacific	3039
Panasonic	3001, 3013
Paragon	3001
Philips	3061, 3054, 3055, 3056, 3065, 3069, 3071
Pulsar	3001
Pioneer	3010, 3014, 3018, 3036
VVP Stereo	3002

Visual Matrix		
Quasar	3001	
Radio Shack	3051, 3070 3072 3073	
Rembrandt	3004	
Runco	3001	
Salora	3026	
Samsung	3014, 3040	
Satbox	3024	
Scientific	3003, 3032, 3049	
Scientific Atlanta	3003, 3008, 3021	
Seawoo	3045	
Signal	3007	
Signature	3004	
Starcom	3002, 3007	
Stargate	3007	
Starquest	3007	
STS	3015	
Taihan	3043	
Teleservice	3022	
Tele+I	3028	
Tudi	3023	
Tusa	3007	
Tocom	3005	
Tongkook	3042, 3048	
Toshiba	3001	
United Cable	3002	
Universal	3061, 3053, 3060, 3062, 3063	
Videoway	3017	
Viewstar	3059, 3055, 3058, 3064, 3066	
Visicable+	3033	
Westminster	3012	
Wolsey Gene	3037	
Zenith	3001, 3034	

---

## SATELLITE TUNER

Absat	4006	
AST	4027	
Alba	4029, 4034, 4037, 4052	
Aldes	4019	
Amstrad	4003, 4016, 4025, 4038, 4039, 4042	
Ankard	4013, 4019, 4030, 4044	
Anttron	4009, 4034	
Armstrong	4015	
Astra	4005	
Astro	4008, 4039, 4045	
Avalon	4031	
Axis	4030, 4046	
Beko	4010	
Best	4030	
Blaupunkt	4008	
Boca	4015, 4043	
Brain Wave	4022	
British Sky	4058	
Broadcasting		
BT	4053	
Bush	4002	
CNT	4045	
Cambridge	4024	
Canal Satellite	4059	
Canal+	4059	
Channel Master	4029	
Comlink	4019	
Connexions	4031	
Crown	4015	
Cyrus	4011	
D-Box	4054	
DDC	4029	
DNT	4011, 4031	
Echostar	4031, 4036, 4061	
Emanon	4034	
Ferguson	4002, 4009, 4010, 4023	
Fidelity	4016	
Finlux	4005, 4024, 4032, 4037	
Fracarro	4061	
Freecom	4034	
Fujitsu	4094 4012	
FTE Humax	4060	
Fube	4030, 4031, 4034	
G-sat	4009	
Galaxis	4019, 4057, 4060	
General Instrument	4085, 4080, 4069, 4082, 4083, 4092	
Gold Box	4059	
Gooding	4048	
Goodmans	4010	
Grundig	4008, 4010, 4048	
Hinari	4009	
Hirschmann	4008, 4032, 4039, 4040, 4049	
Hitachi	4037	
Houston	4053	
Hughes	4088	
Huth	4013, 4015, 4019, 4026	
ITT	4005	
Invideo	4061	
Intervision	4050	
Johansson	4022	
JVC	4048	
Kathrein	4004, 4006, 4008, 4011, 4035, 4041	
Kreiselmeier	4008	
Kyostar	4034	
La Sat	4043, 4045	
Lenco	4034	
Lennox	4050	
Lupus	4030	
Luxor	4005, 4049	
Magnavox	4087	
Manhattan	4037, 4045, 4050	
Marantz	4011	
Maspro	4004, 4023	
Matsui	4024, 4048	
Mediasat	4059	
Mediamarkt	4015	
Minerva	4048	
Morgan's	4015, 4043	
Navex	4022	
Neuhaus	4039	
Neusat	4057	
Newhaus	4013	
Nikko	4028	
Nokia	4005, 4032, 4037, 4049, 4054, 4063	
Nordmende	4029	
Orbitech	4039	
Oxford	4024	
Pace	4002, 4009, 4014, 4023, 4037, 4055, 4058	
Palladium	4048	
Palsat	4039	
Panda	4037	
Panasonic	4086, 4077	
Philips	4007, 4011, 4020, 4037, 4048, 4059	
Phonotrend	4019, 4050	
Pioneer	4021, 4059	
Planet	4061	
Promax	4037	
Prosat	4019	
Quadral	4029, 4044	
Radio shack	4083	
Radiola	4011	
Radix	4031, 4064	
RCA	4084, 4076, 4090	
RFT	4011, 4013, 4019	
Saba	4023, 4045	
Sabre	4037	
Sagem	4056	
Salora	4005	
Samsung	4066, 4067, 4068	
SAT	4027, 4038	
Satcom	4026, 4051	
Satec	4009	
Satmaster	4026	
Satpartner	4022, 4034, 4040, 4045	

Schwaiger	4009, 4041
Seemann	4031, 4046
SEG	4030, 4034
Siemens	4008
Skymaster	4019, 4044, 4051
Sony	4017, 4018
Strong	4062
Sunstar	4043
Tantec	4023, 4037
Technisat	4001, 4039
Techniland	4026
Telefunken	4034
Teleka	4015, 4052
Telesat	4051
Thomson	4037, 4059
Tonna	4026, 4053
Toshiba	4089, 4071, 4075
TPS	4056
Triad	4027
Triasat	4040
Uniden	4093, 4070, 4073, 4074, 4078, 4079, 4081, 4083
Unitor	4022, 4008, 4049
Universum	4011
Ventana	4034
Vortec	4027
Vtech	4022
Winersat	4008, 4027, 4031, 4037
Wisi	4033, 4045, 4047
Xsat	4006, 4065
Xcom Multimedia	4065
Zehnder	4033, 4045, 4047
Zenith	4071, 4072, 4091





© 2005 YAMAHA CORPORATION All rights reserved.

**YAMAHA ELECTRONICS CORPORATION, USA** 6660 ORANGETHORPE AVE., BUENA PARK, CALIF. 90620, U.S.A.  
**YAMAHA CANADA MUSIC LTD.** 135 MILNER AVE., SCARBOROUGH, ONTARIO M1S 3R1, CANADA  
**YAMAHA ELECTRONIK EUROPA G.m.b.H.** SIEMENSSTR. 22-34, 25462 RELINGEN BEI HAMBURG, GERMANY  
**YAMAHA ELECTRONIQUE FRANCE S.A.** RUE AMBROISE CROIZAT BP70 CROISSY-BEAUBOURG 77312 MARNE-LA-VALLEE CEDEX02, FRANCE  
**YAMAHA ELECTRONICS (UK) LTD.** YAMAHA HOUSE, 200 RICKMANSWORTH ROAD WATFORD, HERTS WD18 7GQ, ENGLAND  
**YAMAHA SCANDINAVIA A.B.** J A WETTERGRENS GATA 1, BOX 30053, 400 43 VÄSTRA FRÖLUNDA, SWEDEN  
**YAMAHA MUSIC AUSTRALIA PTY, LTD.** 17-33 MARKET ST., SOUTH MELBOURNE, 3205 VIC., AUSTRALIA

**YAMAHA CORPORATION**  
Printed in China ◀ 3139 246 16151